



***Valve Automation
since 1976***



***TruTorq
Pneumatic
Rack & Pinion
Actuators***

INDEX

- Product Description.....3
- Actuator Mounting.....4
- Torque Diagram.....5
- Double Acting Actuator Operation.....6
- Spring Return Actuator Operation.....7
- Double Acting Torque Table (NM – in.lbs).....8
- Spring Return Torque Table (NM).....9
- Spring Return Torque Table (in.lbs)..... 10
- Part Number Breakdown..... 11
- S-Type Actuator Part List – 1 –..... 12
- S-Type Actuator Dimensions – 1 – (metric)..... 13
- S-Type Actuator Dimensions – 1 – (imperial)..... 13
- S-Type Actuator Part List – 3 - 10 –..... 14
- S-Type Actuator Dimensions – 3 - 10 – (metric)..... 15
- S-Type Actuator Dimensions – 3 - 10 – (imperial)..... 15
- C-Type Actuator Benefit..... 16
- C-Type Actuator Part List – 2 - 150 –..... 17
- C-Type Actuator Dimensions – 2 - 150 – (metric)..... 18
- C-Type Actuator Dimensions – 2 - 150 – (imperial)..... 19
- C-Type Actuator Part List – 250 –..... 20
- C-Type Actuator Part List – 400 –..... 21
- C-Type Actuator Dimensions – 250 - 400 – (metric)..... 22
- C-Type Actuator Dimensions – 250 - 400 – (imperial)..... 23
- 180° C-Type Actuator Part List – 2 - 35 –..... 24
- 180° C-Type Actuator Dimensions – 2 - 35 – (metric)..... 25
- 180° C-Type Actuator Dimensions – 2 - 35 – (imperial)..... 25
- E-Type Actuator Benefit..... 26
- E-Type Actuator Part List – 8 - 150 –..... 27
- E-Type Actuator Dimensions – 8 - 150 – (metric)..... 28
- E-Type Actuator Dimensions – 8 - 150 – (imperial)..... 29
- Technical Data:*
- Weight..... 30
- Operating Time..... 30
- Air Consumption..... 30



PRODUCT DESCRIPTION

TruTorq® actuators are designed to combine the perfect balance of power, durability and safety, in a compact and lightweight form. The result is a complete range of actuators for accurate control of valves, in a wide range of applications.

The basic design is of double rack and pinion.

Standard features are:

- Anodized aluminum body
- Epoxy painted aluminum endcaps
- Zinkplated steel driveshaft
- Stainless steel bolts

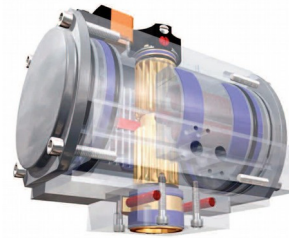

Options: High temperature, Low Temperature, Fast Acting.

Special treatment (CNI®) that allows to replace stainless steel actuators on pharmaceutical or food and beverage plants available as option.

Actuators are designed to and in compliance with the following standards:

- ISO 5211 - Actuator to Valve Interface Standard
- DIN 3337 - 45° Orientation of the Square Drive Shaft
- VDI/VDE 3845 - Standard for Namur mounting of accessories (switchboxes, solenoid valves, positioners)
- ATEX - Explosive Atmosphere Directive (2014/34/EU)
- PED - Pressure Equipment Directive (2014/68/EU)

Production facility in North of Italy, this provides us with fast and efficient access to some of the best technology and know-how in the world.

The factory operates a quality assurance plan to ISO 9001:2015 which is certified by TUV Sud as well as ISO 14001 and ISO 45001

Leakage test of 100% actuators before shipping.

Constant monitoring of all components through 3D measuring systems.

Experienced and dedicated engineering team continually look for improvement of the products, new technologies, techniques and manufacturing processes.



ACTUATOR MOUNTING

Below are the two common variations to mounting a 90 or 180 degree actuator on a valve.

1. in-line or parallel to the pipe, actuator and valve are in the standard closed position
2. in-line or parallel to the pipe, actuator and valve are in the standard open position
3. crossmount or offset to the pipe, actuator and valve are in the standard closed position
4. crossmount or offset to the pipe, actuator and valve are in the standard open position

Mounting actuators in these varying positions is due to space constraints in the global assembly or simply due to consistency with prior assemblies already in existence. Please note how the indicator puck always correctly shows the position of the valve disc and hence showing the flowpath of the medium running through the pipe.

1. In-line CLOSED position



2. In-line OPEN position



3. Crossmount CLOSED position

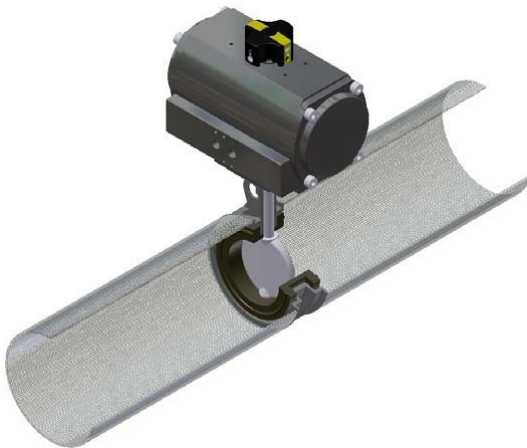

4. Crossmount OPEN position

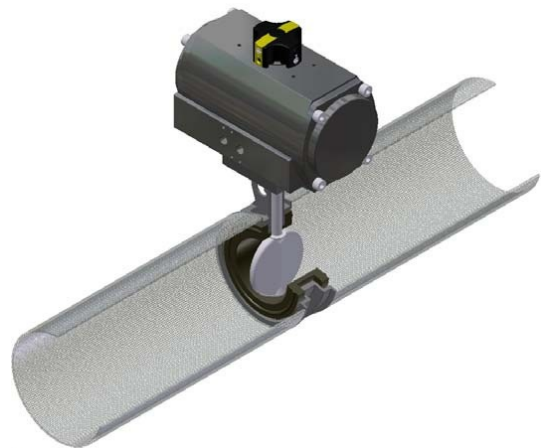

TORQUE DIAGRAM

Double Acting Torque Diagram

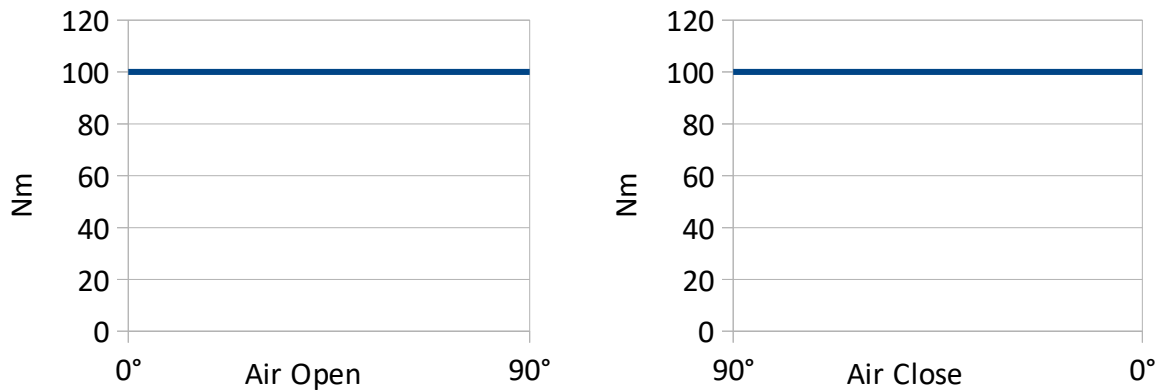

With Reference to the above diagram, it can be noted that the torque of a Rack and Pinion Double Acting “DA” Actuator remains constant through-out the complete action.

Spring Return Torque Diagram

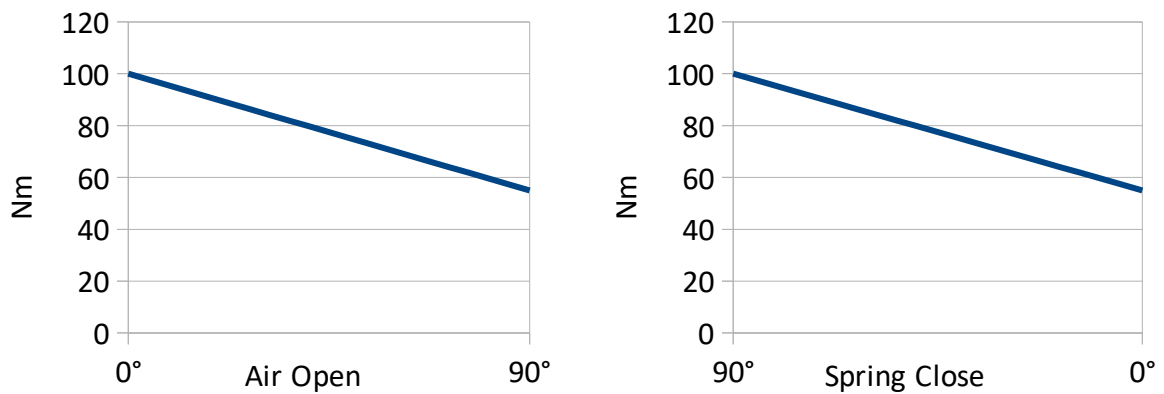

With Reference to the above diagram, the torque of the Spring Return “SR” Actuator is not constant but decreasing due to the action of the springs that when compressed, during air actuation, counteract the pistons movement and accumulate energy which will be available in a decreasing way during the rotation inversion.



DOUBLE ACTING ACTUATOR OPERATION

Opening Stroke



- Looking at the front of the Actuator, Port “A” is on the left and Port “B” is on the right
- To open the Actuator, connect the air supply to Port “A” to fill the central chamber
- The two Pistons will open and rotate the Driveshaft in counter-clockwise direction
- When the Pistons reach the end of their travel, the Actuator Driveshaft will be in the open position

Closing Stroke



- Looking at the front of the Actuator, Port “A” is on the left and Port “B” is on the right
- To close the Actuator, connect the air supply to Port “B” to fill the outer chamber
- The two Pistons will close and rotate the Driveshaft in clockwise direction
- When the Pistons reach the end of their travel, the Actuator Driveshaft will be in the closed position



SPRING RETURN ACTUATOR OPERATION

Opening Stroke



- Looking at the front of the Actuator, Port “A” is on the left and Port “B” is on the right
- To open the Actuator, connect the air supply to Port “A” to fill the central chamber
- The two Pistons will open, compressing the Springs and rotate the Driveshaft in counter-clockwise direction
- When the Pistons reach the end of their travel, the Springs will be fully compressed and the Actuator Driveshaft will be in the open position

Closing Stroke



- Looking at the front of the Actuator, Port “A” is on the left and Port “B” is on the right
- To close the Actuator, disconnect the air supply from Port “A”. This will allow the compressed Springs to push the Pistons back to their starting position
- While the Springs decompress, the two Pistons will close and rotate the Driveshaft in clockwise direction
- When the Pistons reach the end of their travel, the Actuator Driveshaft will be in the closed position



DOUBLE ACTING TORQUE TABLE

SIZE	AIR SUPPLY (Bar)						
	2	3	4	5	5,5	6	7
1	2,9	4,4	5,9	7,3	8,1	8,8	10,3
3	7,9	11,9	15,8	19,8	21,7	23,7	27,7
5	16,9	25,4	33,8	42,3	46,5	50,7	59,2
10	33,8	50,7	67,6	84,5	93,0	101,4	118,3
2	6,8	10,3	13,7	17,1	18,8	20,5	23,9
4	13,9	20,8	27,7	34,7	38,1	41,6	48,5
8	30,0	45,0	60,0	75,0	82,5	90,0	105,0
12	40,8	61,3	81,7	102,1	112,3	122,5	142,9
20	67,3	101,0	134,6	168,3	185,1	201,9	235,6
35	124,7	187,0	249,3	311,7	342,8	374,0	436,3
55	199,0	298,5	398,0	497,5	547,3	597,0	696,5
70	275,0	412,5	550,0	687,5	756,3	825,0	962,5
100	374,0	561,0	748,0	935,0	1028,5	1122,0	1309,0
150	551,7	827,5	1103,3	1379,2	1517,1	1655,0	1930,8
250	882,7	1324,0	1765,3	2206,7	2427,3	2648,0	3089,3
400	1601,0	2401,5	3202,0	4002,5	4402,8	4803,0	5603,5

Nm

SIZE	AIR SUPPLY (PSI)						
	40	50	60	70	80	90	100
1	32,6	40,7	48,8	57,0	65,1	73,2	81,4
3	96,0	120,0	144,0	168,0	192,0	216,0	240,0
5	206,0	257,5	309,0	360,5	412,0	463,5	515,0
10	413,5	516,9	620,3	723,6	827,0	930,4	1033,8
2	83,0	103,8	124,5	145,3	166,0	186,8	207,5
4	168,5	210,6	252,8	294,9	337,0	379,1	421,3
8	365,0	456,3	547,5	638,8	730,0	821,3	912,5
12	497,0	621,3	745,5	869,8	994,0	1118,3	1242,5
20	819,0	1023,8	1228,5	1433,3	1638,0	1842,8	2047,5
35	1527,5	1909,4	2291,3	2673,1	3055,0	3436,9	3818,8
55	2371,0	2963,8	3556,5	4149,3	4742,0	5334,8	5927,5
70	3344,5	4180,6	5016,8	5852,9	6689,0	7525,1	8361,3
100	4552,5	5690,6	6828,8	7966,9	9105,0	10243,1	11381,3
150	6712,5	8390,6	10068,8	11746,9	13425,0	15103,1	16781,3
250	10740,0	13425,0	16110,0	18795,0	21480,0	24165,0	26850,0
400	19485,5	24356,9	29228,3	34099,6	38971,0	43842,4	48713,8

in.lbs



SPRING RETURN TORQUE TABLE (Nm)

SIZE	N° Springs	Spring Torque		AIR SUPPLY (Bar)							
				4		5		5,5		6	
		0°	90°	0°	90°	0°	90°	0°	90°	0°	90°
3	8	5,4	10,5	10,4	5,3	11,8	7,9	16,4	11,2	18,3	13,2
	10	6,7	13,1	9,1	2,7	13,1	6,7	15,0	8,6	17,0	10,6
	11	7,4	14,4			12,4	5,3	14,4	7,3	16,3	9,3
	12	8,0	15,7					13,7	6,0	15,7	8,0
5	8	12,0	21,8	21,8	12,0	30,3	20,5	34,5	24,7	38,7	28,9
	10	15,0	27,2	18,8	6,6	27,3	15,1	31,5	19,3	35,7	23,5
	11	16,5	29,9			25,8	12,4	30,0	16,6	34,2	20,8
	12	18,0	32,6					28,5	13,8	32,7	18,1
10	8	26,7	41,0	40,9	26,6	57,8	43,5	66,2	52,0	74,7	60,4
	10	33,4	21,2	34,2	24,6	51,1	33,3	59,6	41,8	68,0	50,2
	11	36,7	56,3			47,8	28,2	56,2	36,6	64,7	45,1
	12	40,1	61,4					52,9	31,5	61,3	40,0
2	4/0	4,8	8,8	8,8	4,9	12,3	8,3	14,0	10,0	15,7	11,7
	4/2	6,1	11,0	7,6	2,7	11,0	6,1	12,8	7,8	14,5	9,5
	4/3	6,7	12,1			10,4	5,0	12,1	6,7	13,9	8,4
	4/4	7,3	13,2					11,5	5,6	13,2	7,3
4	4/0	9,8	17,8	17,9	9,9	24,9	16,8	28,3	20,3	31,8	23,8
	4/2	12,2	22,2	15,5	5,5	22,4	12,4	25,9	15,9	29,4	19,3
	4/3	13,4	24,5			21,2	10,2	24,7	13,6	28,1	17,1
	4/4	14,6	26,7					23,5	11,4	26,9	14,9
8	4/0	21,1	38,4	38,9	21,6	53,9	36,6	61,4	44,1	68,9	51,6
	4/2	23,8	43,2	33,6	12,0	48,6	27,0	56,1	34,5	63,6	42,0
	4/3	29,0	52,8			46,0	22,2	53,5	29,7	61,0	37,2
	4/4	31,7	57,6					50,8	24,9	58,3	32,4
12	4/0	28,8	52,4	52,9	29,3	73,3	49,7	83,5	59,9	93,7	70,1
	4/2	36,0	65,5	54,7	16,2	66,1	36,6	76,3	46,8	86,5	57,0
	4/3	39,6	72,1			62,5	30,0	72,7	40,3	82,9	50,5
	4/4	43,2	78,6					69,1	33,7	79,3	43,9
20	4/0	47,7	86,8	86,9	47,8	120,6	81,5	137,4	98,3	154,2	115,1
	4/2	53,7	108,5	75,0	26,1	108,6	59,8	125,4	76,6	142,3	93,4
	4/3	65,5	119,4			102,6	48,9	119,5	65,8	136,3	82,6
	4/4	71,6	130,2					113,5	54,9	130,3	71,7
35	4/0	88,4	160,8	161,0	88,7	223,4	151,0	254,6	182,2	285,7	213,4
	4/2	110,5	201,0	138,9	48,5	201,3	110,8	232,5	142,0	263,6	173,2
	4/3	121,6	221,1			190,2	90,7	221,4	121,9	252,6	153,1
	4/4	132,6	241,2					210,4	101,8	241,5	133,0
55	4/0	141,0	256,4	256,8	141,4	356,3	240,9	406,0	290,6	455,7	340,3
	4/2	176,3	320,5	221,5	77,3	321,0	176,8	370,7	226,5	420,5	279,2
	4/3	193,9	352,6			303,4	144,7	353,1	194,5	402,8	244,2
	4/4	211,5	384,6					335,5	162,4	385,2	212,1
70	4/0	195,0	354,0	355,0	196,0	493,0	333,0	561,0	402,0	630,0	471,0
	4/2	243,0	443,0	306,0	107,0	444,0	245,0	513,0	314,0	581,0	382,0
	4/3	268,0	487,0			420,0	201,0	488,0	269,0	557,0	338,0
	4/4	292,0	531,0					464,0	225,0	533,0	294,0
100	4/0	265,0	482,0	483,0	266,0	670,0	453,0	764,0	547,0	857,0	640,0
	4/2	331,0	603,0	417,0	146,0	604,0	333,0	697,0	426,0	791,0	520,0
	4/3	365,0	663,0			571,0	272,0	664,0	366,0	758,0	459,0
	4/4	398,0	723,0					631,0	306,0	725,0	399,0
150	4/0	391,0	711,0	712,0	392,0	988,0	668,0	1126,0	806,0	1264,0	944,0
	4/2	489,0	889,0	615,0	215,0	890,0	491,0	1028,0	629,0	1166,0	766,0
	4/3	538,0	977,0			842,0	402,0	979,0	540,0	1117,0	678,0
	4/4	586,0	1066,0					931,0	451,0	1069,0	589,0
250	6	606,0	936,0	1159,0	829,0	1600,0	1270,0	1821,0	1491,0	2042,0	1712,0
	8	808,0	1248,0	957,0	517,0	1398,0	958,0	1619,0	1179,0	1840,0	1400,0
	10	1010,0	1560,0			1196,0	646,0	1417,0	867,0	1638,0	1088,0
	12	1212,0	1872,0					1215,0	555,0	1436,0	776,0
400	10	1180,0	1820,0	2022,0	1382,0	2823,0	2183,0	3223,0	2583,0	3623,0	2983,0
	12	1416,0	2184,0	1786,0	1018,0	2587,0	1819,0	2987,0	2219,0	3387,0	2619,0
	15	1770,0	2730,0			2233,0	1273,0	2633,0	1673,0	3033,0	2073,0
	16	1888,0	2912,0					2515,0	1491,0	2915,0	1891,0



SPRING RETURN TORQUE TABLE (in.lbs)

SIZE	N° Springs	Spring Torque		AIR SUPPLY (psi)							
				60		70		80		90	
		0°	90°	0°	90°	0°	90°	0°	90°	0°	90°
3	8	47	93	97	51	121	75	145	99	169	123
	10	59	116	84	28	108	52	132	76	156	100
	11	65	128			103	40	127	64	151	88
	12	71	139					121	53	145	77
5	8	106	193	202	115	253	167	304	218	356	269
	10	133	241	175	68	227	119	278	170	329	222
	11	146	265			213	95	265	146	316	198
	12	159	289			200	70	252	122	303	173
10	8	236	362	379	254	482	356	584	459	687	562
	10	296	188	321	230	423	299	526	369	629	438
	11	325	498			393	220	496	323	599	426
	12	355	544					467	278	570	381
2	4/0	42	78	82	47	103	67	124	88	144	109
	4/2	54	97	71	27	92	48	113	69	134	90
	4/3	59	107			86	38	107	59	128	80
	4/4	65	117					101	49	122	70
4	4/0	87	158	166	95	208	137	250	179	292	221
	4/2	108	196	144	56	186	98	229	140	271	182
	4/3	119	217			176	78	218	120	260	162
	4/4	129	236					207	101	249	143
8	4/0	187	340	360	207	451	298	542	389	633	480
	4/2	211	382	319	133	407	219	495	304	583	390
	4/3	257	467			381	171	472	262	563	353
	4/4	281	510					448	220	539	311
12	4/0	255	464	489	281	613	405	737	529	861	653
	4/2	319	580	425	165	549	289	673	413	797	537
	4/3	350	638			518	231	642	356	766	480
	4/4	382	696					610	297	734	422
20	4/0	422	768	804	459	1008	663	1213	867	1417	1072
	4/2	475	960	711	267	909	471	1107	676	1304	880
	4/3	580	1057			850	376	1055	581	1259	785
	4/4	634	1152					1002	484	1206	689
35	4/0	782	1423	1489	850	1868	1229	2247	1608	2625	1987
	4/2	978	1779	1294	495	1673	874	2052	1253	2430	1632
	4/3	1076	1957			1575	697	1954	1076	2333	1455
	4/4	1174	2135					1857	898	2235	1277
55	4/0	1248	2269	2375	1356	2979	1960	3583	2564	4187	3169
	4/2	1560	2836	2063	790	2667	1394	3271	1999	3875	2603
	4/3	1716	3121			2512	1112	3116	1716	3720	2321
	4/4	1872	3404					2961	1433	3565	2038
70	4/0	1726	3133	3282	1877	4116	2712	4951	3548	5785	4383
	4/2	2151	3921	2858	1098	3692	1935	4527	2771	5362	3607
	4/3	2372	4310			3472	1538	4306	2374	5141	3209
	4/4	2584	4699					4095	1986	4929	2821
100	4/0	2345	4266	4470	2554	5606	3690	6742	4827	7878	5964
	4/2	2929	5337	3881	1485	5016	2622	6151	3759	7286	4896
	4/3	3230	5868			4723	2093	5860	3230	6996	4367
	4/4	3522	6399					5568	2700	6705	3838
150	4/0	3460	6292	6587	3761	8262	5437	9937	7113	11611	8788
	4/2	4328	7868	5722	2196	7397	3873	9072	5551	10747	7228
	4/3	4761	8646			6964	3089	8639	4765	10314	6442
	4/4	5186	9434					8216	3980	9891	5657
250	6	5363	8284	10711	7797	13391	10477	16070	13158	18749	15838
	8	7151	11045	8928	5042	11607	7723	14287	10404	16967	13085
	10	8939	13806			9824	4969	12505	7651	15185	10333
	12	10726	16567					10722	4898	13403	7581
400	10	10443	16107	18721	13069	23581	17931	28442	22794	33302	27657
	12	12532	19328	16636	9854	21498	14718	26359	19582	31221	24446
	15	15665	24161			18373	9898	23235	14764	28098	19629
	16	16709	25771					22194	13158	27057	18024



PART NUMBER BREAKDOWN

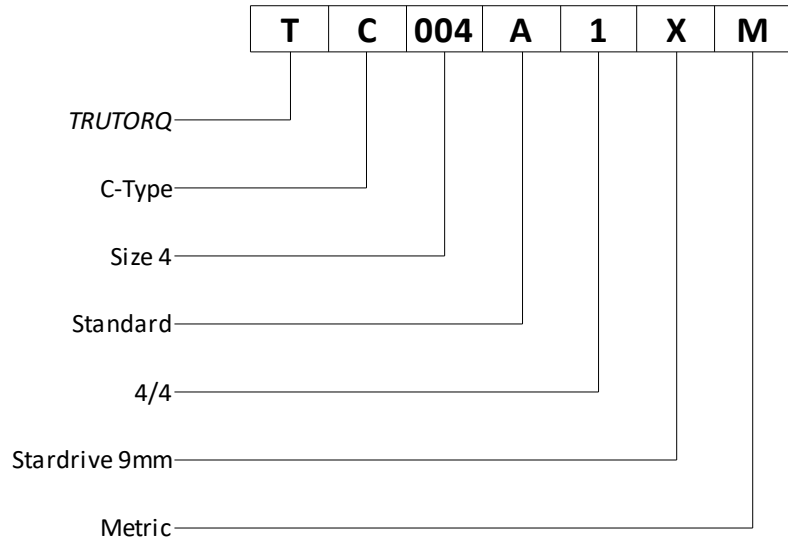

Label	Type	Size	Finish	Action	Shaft	Threading	Optional Codes
T = Trutorq	C = C-Type	C-Type 002	A = Standard	C & E-Type	Stardrive Square	M = Metric	VS = Viton Seal
	E = E-Type	004	C = CNI	0= DA	C-Type 002 X = 09 mm	U = Imperial	XM = Crossmount
	S = S-Type	008	E = Epoxy	1= SR 4/4	004 X = 11 mm		FO = Fail Open
	X = 180° C-Type	012	P = Polyester	2= SR 4/3	008 X = 14 mm		FA = Fast Acting
		020		3= SR 4/2	012 X = 17 mm		HT = High Temperature
		035		4= SR 4/1	020 X = 17 mm		LT = Low Temperature
		055		5= SR 4/0	035 X = 22 mm		
		070		C-Type 250	055 X = 27 mm		
		100		0= DA	070 X = 27 mm		
		150		1= SR 12	100 X = 36 mm		
		250		3= SR 10	150 X = 36 mm		
		400		5= SR 8	250 X = 46 mm		
	E-Type 008			7= SR 6	400 X = 55mm		
		012		C-Type 400	S-Type 001 X = 09 mm		
		020		0= DA	003 F03 X = 09 mm		
		035		1= SR 16	003 F04 Z = 11 mm		
		055		2= SR 15	005 X = 14 mm		
		070		5= SR 12	010 X = 14 mm		
		100		7= SR 10	180° 002 X = 09 mm		
		150		8= SR 9	C-Type 004 X = 11 mm		
	S-Type 001			S-Type	008 X = 14 mm		
		003		0= DA	012 X = 17 mm		
		005		1= SR 12	020 X = 17 mm		
		010		2= SR 11	035 X = 22 mm		
	180° 002			3= SR 10	Size		
	C-Type 004			5= SR 8	E-Type 008 X = F05		
		008			Z = F07		
		012			012 X = F05		
		020			Z = F07		
		035			020 X = F07		
					035 X = F07		
					Z = F10		
					055 X = F10		
					Z = F12		
					070 X = F10		
					Z = F12		
					100 X = F14		
					150 X = F14		



S-TYPE ACTUATOR PART LIST – 1 –

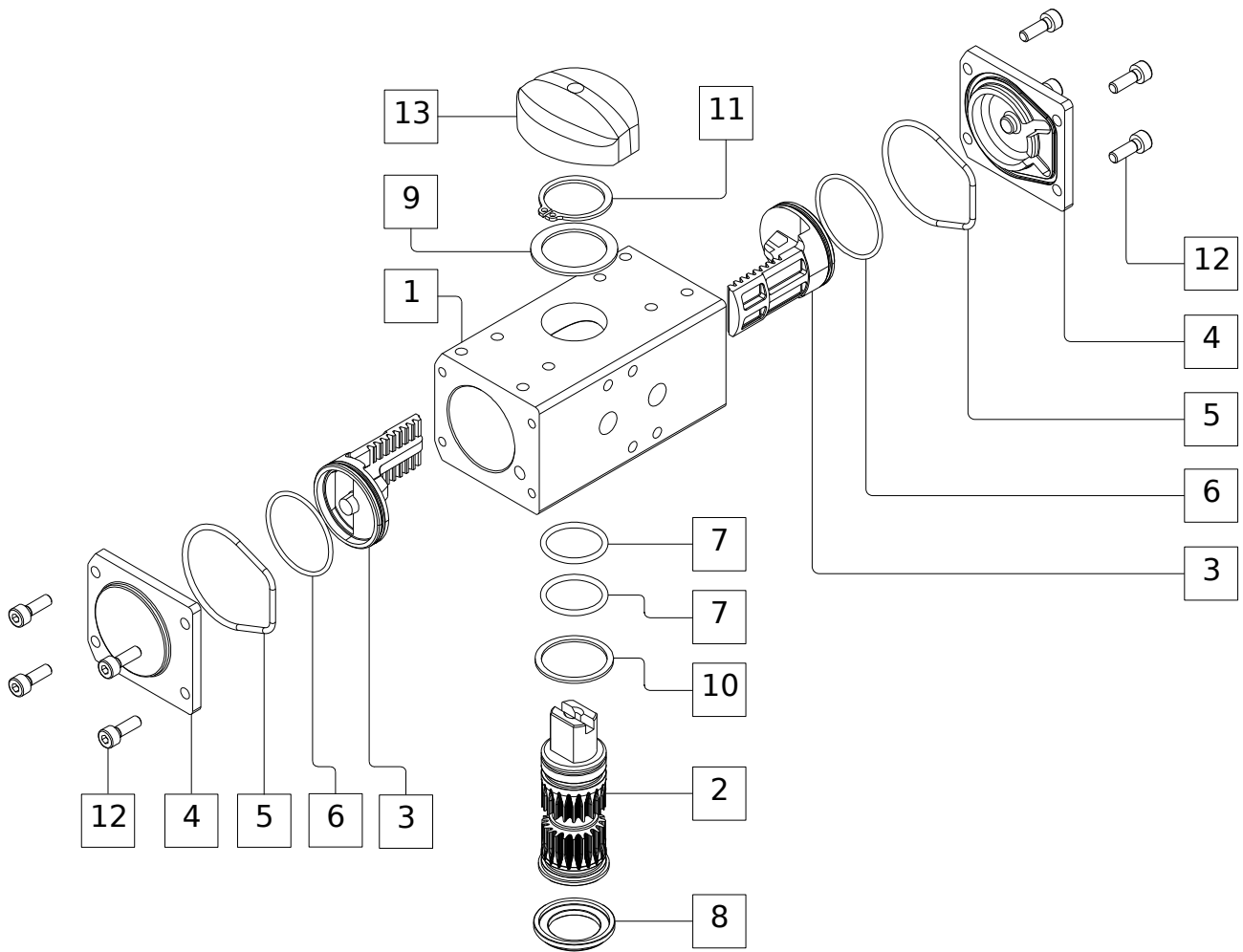

Ref. No	Description	Quantity	Material
1	Body	1	Aluminum, Anodized
2	Driveshaft	1	Steel, Zinkplated
3	Piston	2	POM
4	Endcap	2	POM
5	Endcap O-ring	2	NBR
6	Piston O-ring	2	NBR
7	Driveshaft O-ring	2	NBR
8	Centralisation ring	1	POM
9	Driveshaft Upper Washer	1	POM
10	Driveshaft Lower Washer	1	POM
11	Driveshaft Circlip	1	Steel, Nickelplated
12	Endcap Bolt	8	Stainless Steel
13	Position Indicator	1	POM



S-TYPE ACTUATOR DIMENSIONS – 1 –

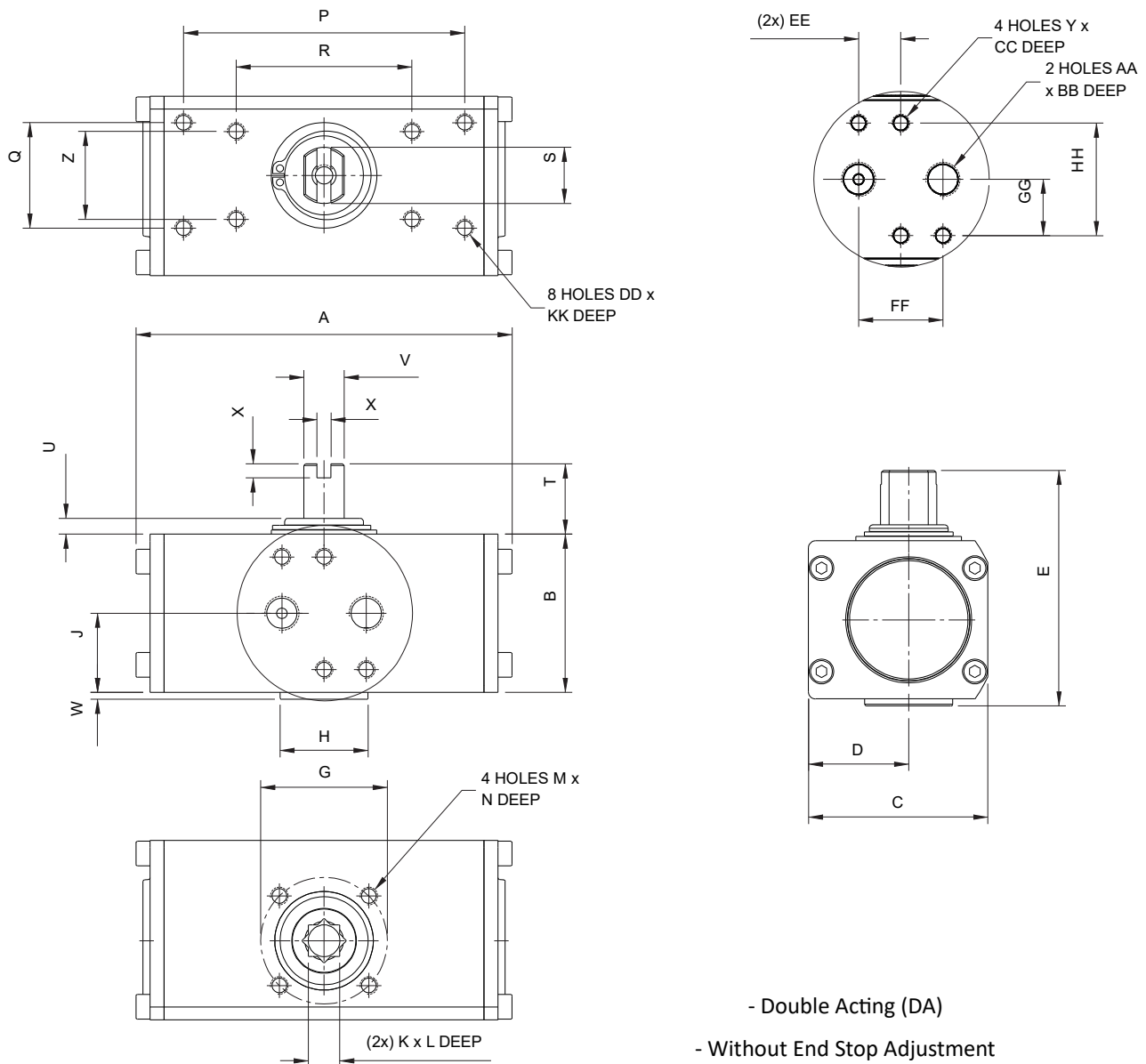

Dimensions Metric (mm)

SIZE	ISO	A	B	C	D	E	G	H	J	K	L	M	N	P	Q	R	∅S
1	F03	113,0	45,0	51,0	28,5	67,0	36,0	25,0	22,5	9,0	11,0	M5	8,0	80,0	30,0	50,0	16,0

SIZE	ISO	T	U	V	W	X	Y	Z	AA (GAS)	BB	CC	DD	EE	FF	GG	HH	KK
1	F03	20,0	4,5	11,5	2,0	4,0	M5	25,0	1/8	7,0	8,0	M5	12,0	24,0	16,0	32,0	5,0

Dimensions Imperial (inches)

SIZE	ISO	A	B	C	D	E	G	H	J	K	L	M	N	P	Q	R	∅S
1	F03	4,45	1,77	2,01	1,12	2,64	1,42	0,98	0,89	0,35	0,43	10-32	0,31	3,15	1,18	1,97	0,63

SIZE	ISO	T	U	V	W	X	Y (UNF)	Z	AA (NPT)	BB	CC	DD (UNF)	EE	FF	GG	HH	KK
1	F03	0,79	0,18	0,45	0,08	0,16	10-32	0,98	1/8	0,28	0,31	10-32	0,47	0,94	0,63	1,26	0,20



S-TYPE ACTUATOR PART LIST – 3 - 10 –

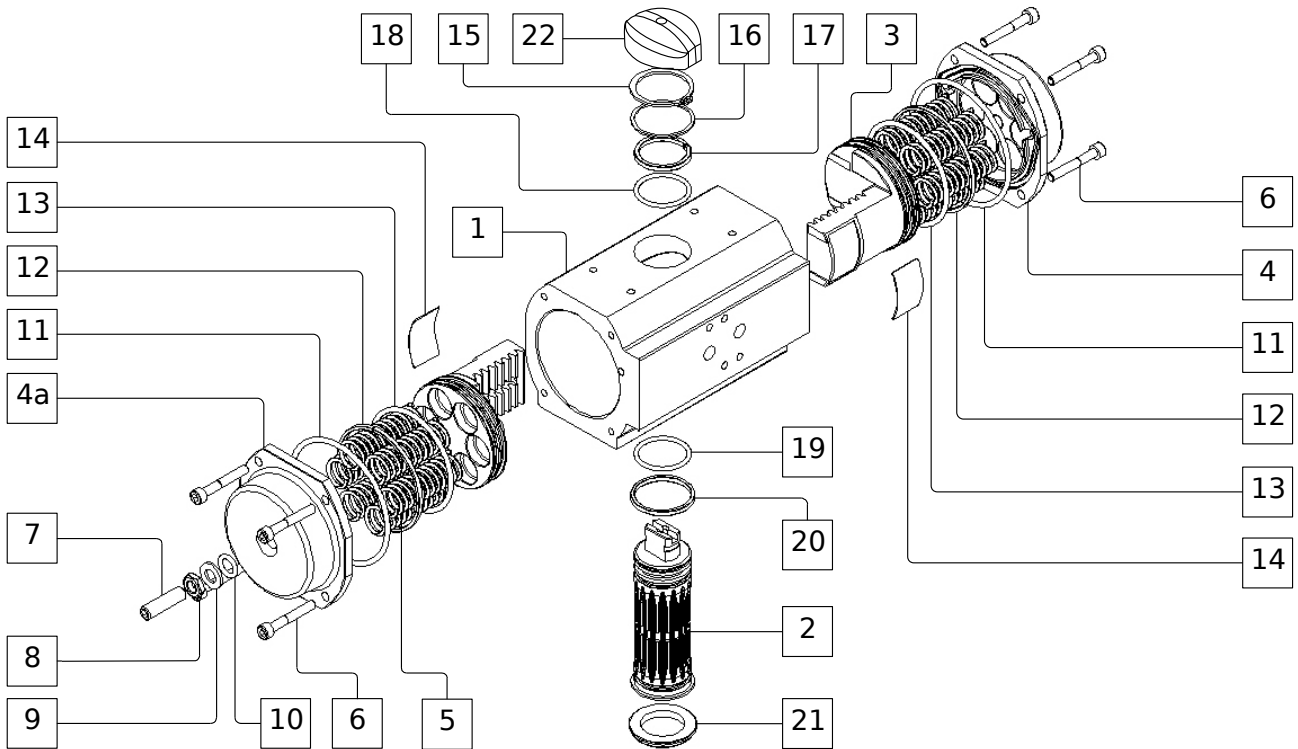

Ref. No	Description	Quantity	Material
1	Body	1	Aluminum, Anodized
2	Driveshaft	1	Steel, Zinkplated
3	Piston	2	Aluminum
4	Endcap	1	Aluminum, Polyester Coated
4 a	Endcap with stop adjustment	1	Aluminum, Polyester Coated
5	Spring	Max 12	SiCr
6	Endcap Bolt	8	Stainless Steel
7	Stop Adjustment Screw	1	Stainless Steel
8	Stop Adjustment Nut	1	Stainless Steel
9	Stop Adjustment Washer	1	Stainless Steel
10	Stop Adjustment O-ring	1	NBR
11	Endcap O-ring	2	NBR
12	Piston Back-up Bearing	2	POM
13	Piston O-ring	2	NBR
14	Piston Wearpad	2	POM
15	Driveshaft Washer	1	POM
16	Driveshaft Circlip	1	Steel, Nickelplated
17	Driveshaft Upper O-ring	1	NBR
18	Driveshaft Upper Bearing	1	POM
19	Driveshaft Lower O-ring	1	NBR
20	Driveshaft Lower Bearing	1	POM
21	Centralisation Ring	1	POM
22	Position Indicator	1	POM



S-TYPE ACTUATOR METRIC DIMENSIONS – 3 - 10 –

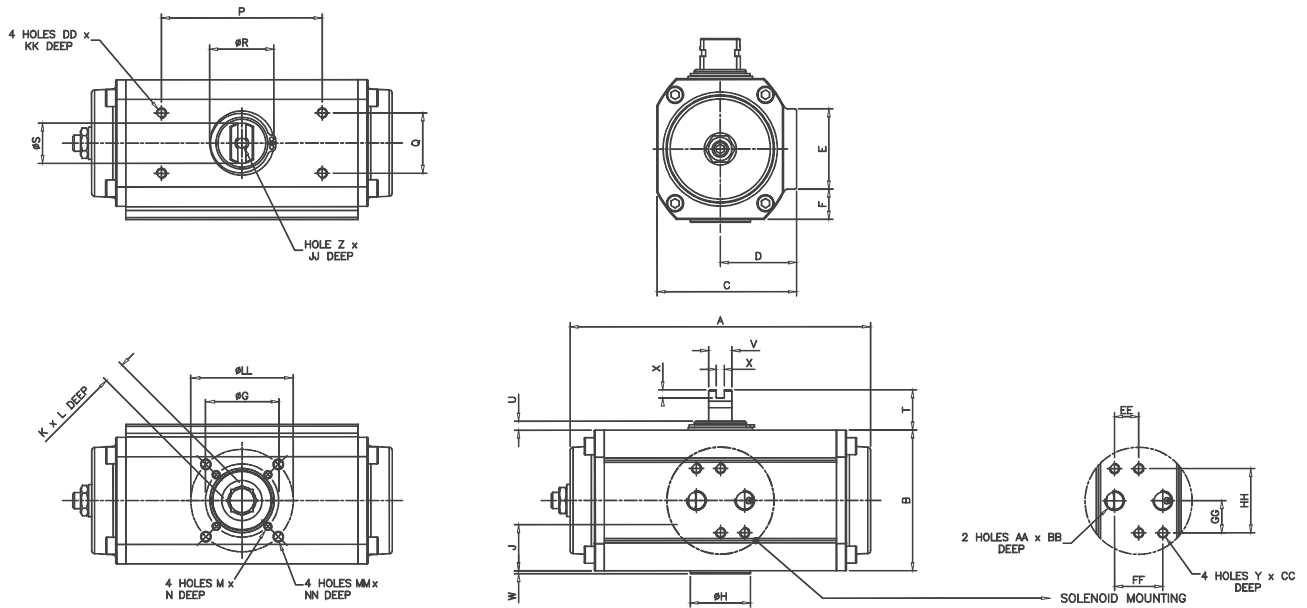

- Double Acting (DA) And Spring Return (SR)
- Single End Stop Adjustment

Dimensions Metric (mm)

ACTUATOR SIZE	ISO	A	B	C	D	E	ØG	ØH	J	K	L	M	N	P	Q	ØR	ØS	T	U
3	F03-F05	149,5	70,0	69,5	38,0	49,0	36,0	25,0	23,0	9,0	11,0	M5	8,0	80,0	30,0	32,0	20,0	20,0	4,5
3	F04	149,5	70,0	69,5	38,0	49,0	42,0	30,0	23,0	11,0	11,0	M5	8,0	80,0	30,0	32,0	20,0	20,0	4,5
5	F05-F07	186,5	87,0	90,5	49,0	49,0	50,0	35,0	34,5	14,0	15,0	M6	10,0	80,0	30,0	32,0	20,0	20,0	4,5
10	F05-F07	206,0	118,0	113,0	59,0	43,0	50,0	35,0	29,5	14,0	19,0	M6	10,0	80,0	30,0	32,0	20,0	20,0	4,5

ACTUATOR SIZE	ISO	V	W	X	Y	Z	AA (GAS)	BB	CC	DD	EE	FF	GG	HH	JJ	KK	ØLL	MM	NN
3	F03-F05	11,5	1,5	4,0	M5	M6	1/8	10,0	8,0	M5	12,0	24,0	16,0	32,0	12,0	8,0	50,0	M6	10,0
3	F04	11,5	1,5	4,0	M5	M6	1/8	10,0	8,0	M5	12,0	24,0	16,0	32,0	12,0	8,0	-	-	-
5	F05-F07	11,5	3,0	4,0	M5	M6	1/8	10,0	8,0	M5	12,0	24,0	16,0	32,0	12,0	8,0	70,0	M8	12,0
10	F05-F07	11,5	2,9	4,0	M5	M6	1/8	10,0	8,0	M5	12,0	24,0	16,0	32,0	12,0	8,0	70,0	M8	13,0

Dimensions Imperial (inches)

ACTUATOR SIZE	ISO	A	B	C	D	E	ØG	ØH	J	K	L	M (UNC)	N	P	Q	ØR	ØS	T	U
3	F03-F05	5,89	2,76	2,74	1,50	1,93	1,42	0,98	0,91	0,35	0,43	10-32	0,31	3,15	1,18	1,26	0,79	0,79	0,18
3	F04	5,89	2,76	2,74	1,50	1,93	1,65	1,18	0,91	0,43	0,43	10-32	0,31	3,15	1,18	1,26	0,79	0,79	0,18
5	F05-F07	7,34	3,43	3,56	1,93	1,93	1,97	1,38	1,36	0,55	0,59	¼-20	0,39	3,15	1,18	1,26	0,79	0,79	0,18
10	F05-F07	8,11	4,65	4,45	2,32	1,69	1,97	1,38	1,16	0,55	0,75	1/4-20	0,39	3,15	1,18	1,26	0,79	0,79	0,18

ACTUATOR SIZE	ISO	V	W	X	Y (UNF)	Z	AA (NPT)	BB	CC	DD (UNF)	EE	FF	GG	HH	JJ	KK	ØLL	MM (UNC)	NN
3	F03-F05	0,45	0,06	0,16	10-32	M6	1/8	0,39	0,31	10-32	0,47	0,94	0,63	1,26	0,47	0,31	1,97	M6	0,39
3	F04	0,45	0,06	0,16	10-32	M6	1/8	0,39	0,31	10-32	0,47	0,94	0,63	1,26	0,47	0,31	-	-	-
5	F05-F07	0,45	0,12	0,16	10-32	M6	1/8	0,39	0,31	10-32	0,47	0,94	0,63	1,26	0,47	0,31	2,76	M8	0,47
10	F05-F07	0,45	0,11	0,16	10-32	M6	1/8	0,39	0,31	10-32	0,47	0,94	0,63	1,26	0,47	0,31	2,76	M8	0,51



C-TYPE ACTUATOR BENEFIT

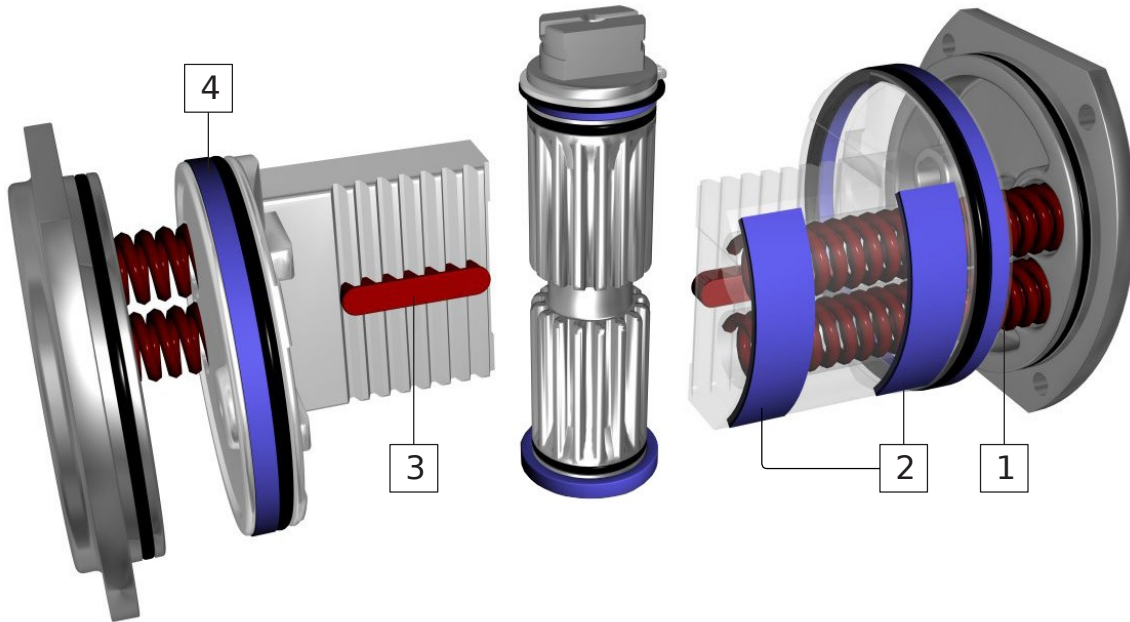

1. SPRINGS

- Springs are located inside the piston rack, same overall dimensions for DA and SR actuators (size 2 – 150)
- No special tools required to change from DA to SR or opposite
- Long bolting is standard feature to fully relax springs

2. PISTON WEAR PADS

- Dual encapsulated “POM” wear pads on the piston, prevent metal to metal contact between piston and cylinder, thus providing low friction travel
- The dual encapsulated “POM” wear pads absorb the adverse side loading at start of each stroke

3. TWIN GUIDE BARS

- Twin guide bars absorb any adverse side loading, from rack at the start of each stroke, which reduces pinion and rack wear

4. BACKUP BEARING

- Piston backup bearings, which are situated behind the pistons o-ring, ensure linear movement and prevent wear on the cylinder surface



C-TYPE ACTUATOR PART LIST – 2 - 150 –

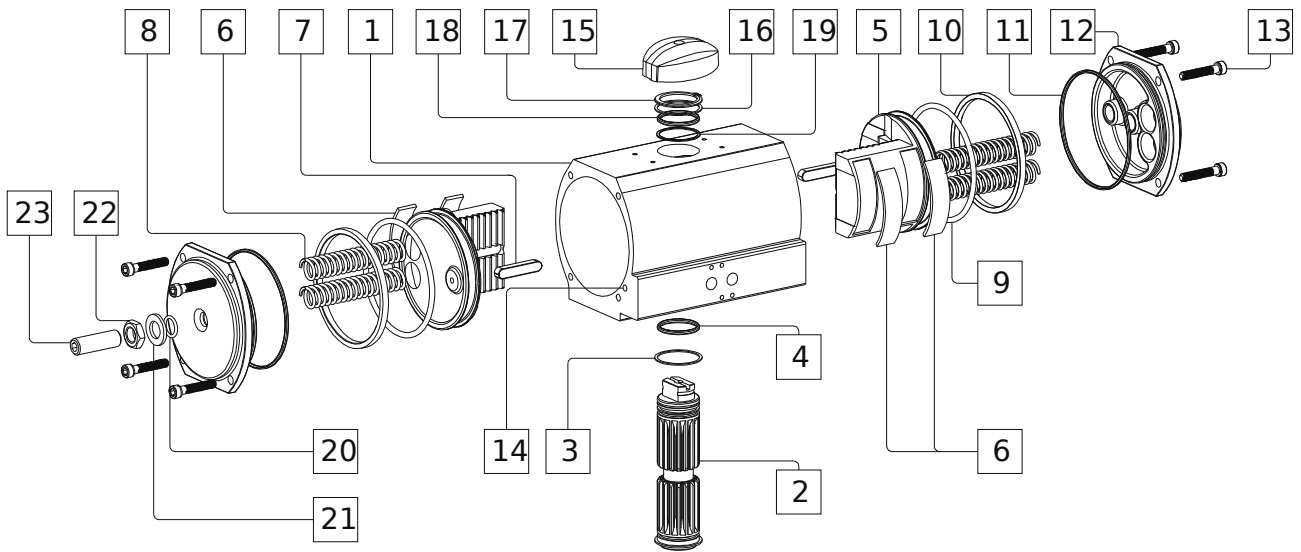

Ref. No	Description	Quantity	Material	
			Standard	CNI®
1	Body	1	Aluminum, Anodized	Aluminum, CNI® treated
2	Driveshaft	1	Steel, Zinkplated	Steel, Nickelplated + Teflon
3	Washer	1	POM	POM
4	Driveshaft Lower O-ring	1	NBR	NBR
5	Piston	2	Aluminum	Aluminum, Anodized
6	Wearpad	4	POM	POM
7	Guide Bar	2	Steel	Steel
8	Spring (Outer/Inner)	Max 4/4	SiCr	SiCr
9	Piston O-ring	2	NBR	NBR
10	Piston Back-up Bearing	2	POM	POM
11	Endcap O-ring	2	NBR	NBR
12	Endcap Plain + Endcap with Adjustment	1 + 1 (2-35) 0 + 2 (55-150)	Aluminum, Polyester Coated	Aluminum, CNI® treated
13	Endcap Bolt	8	Stainless Steel	Stainless Steel
14	Ball Seal	2	NBR	NBR
15	Position Indicator	1	POM	POM
16	Driveshaft Upper Bearing	1	POM	POM
17	Driveshaft Circlip	1	Steel, Nickelplated	Steel, Nickelplated
18	Driveshaft Upper Bearing	1	POM	POM
19	Driveshaft Upper O-ring	1	NBR	NBR
20	Stop Adjustment O-ring	1 (2-35) 2 (55-150)	NBR	NBR
21	Stop Adjustment Washer	1 (2-35) 2 (55-150)	POM	POM
22	Stop Adjustment Nut	1 (2-35) 2 (55-150)	Stainless Steel	Stainless Steel
23	Stop Adjustment Screw	1 (2-35) 2 (55-150)	Stainless Steel	Stainless Steel



C-TYPE ACTUATOR DIMENSIONS – 2 - 150 –

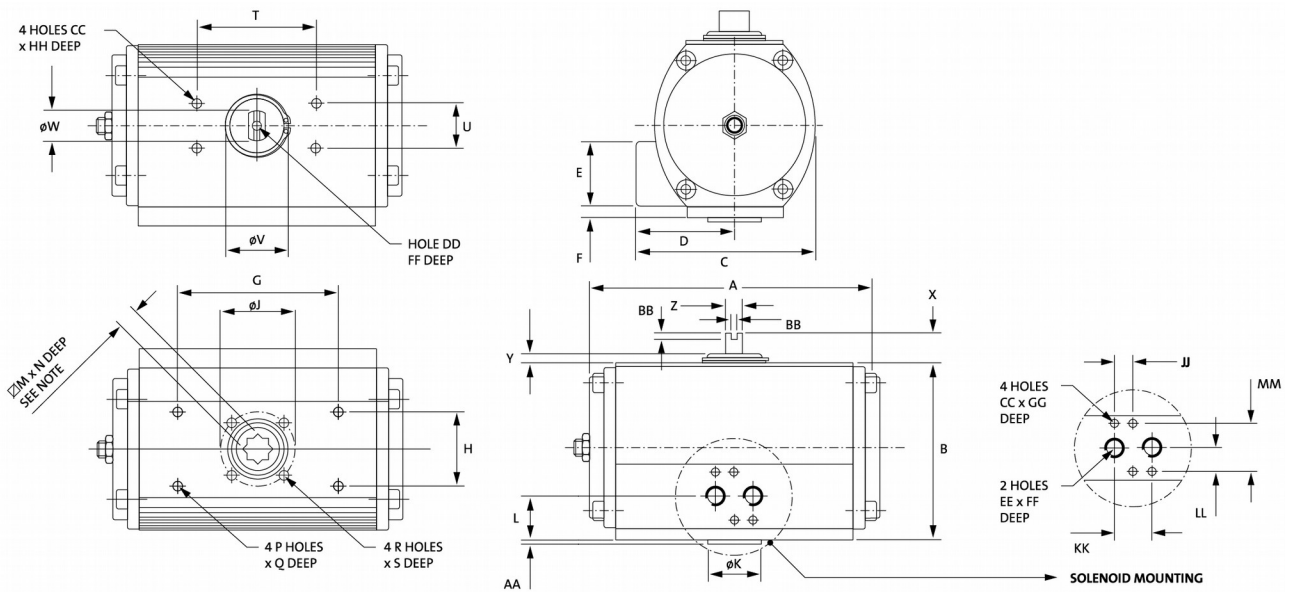

- Double Acting (DA) and Spring Return (SR)

- Single End Stop Adjustment – size 2 – 35 One Side – size 55 – 150 Both Sides

Dimensions Metric (mm)

SIZE	ISO	A	B	C	D	E	F	G	H	Ø J	Ø K	L	M	N	P	Q	R	S	T
2	F03	114,5	73,0	75,5	43,5	41,0	-	73,0	32,0	36,0	25,0	20,5	9,0	10,0	M5	8,0	M5	8,0	80,0
4	F04	133,0	90,5	87,5	47,5	41,0	-	73,0	32,0	42,0	30,0	20,5	11,0	12,0	M5	8,0	M5	8,0	80,0
8	F05-F07	162,0	109,0	105,0	57,0	42,0	7,5	73,0	32,0	50,0	35,0	28,5	14,0	16,0	M6	10,0	M6	10,0	80,0
12	F07-F05	194,0	118,5	121,0	67,0	43,0	8,0	107,0	49,0	70,0	35,0	29,5	17,0	16,0	M6	10,0	M6	10,0	80,0
20	F07-F10	218,0	140,5	136,5	72,0	43,0	8,0	107,0	49,0	70,0	55,0	29,5	17,0	19,0	M6	10,0	M8	13,0	80,0
35	F10-F07	266,0	166,5	156,0	78,0	43,0	8,5	161,0	73,0	102,0	70,0	30,0	22,0	24,0	M6	12,0	M10	16,0	80,0
55	F12-F10	312,0	207,5	191,0	95,5	43,0	20,5	161,0	73,0	125,0	85,0	42,0	27,0	29,0	M8	15,0	M12	20,0	130,0
70	F12-F10	340,0	207,5	191,0	95,5	43,0	20,5	213,0	102,0	125,0	85,0	42,0	27,0	29,0	M8	12,0	M12	20,0	130,0
100	F14	361,0	250,0	227,0	113,5	43,0	39,5	213,0	102,0	140,0	100,0	61,0	36,0	38,0	M10	15,0	M16	25,0	130,0
150	F14	390,0	300,0	280,0	140,0	43,0	56,5	244,0	117,0	140,0	100,0	78,0	36,0	38,0	M12	22,0	M16	25,0	130,0

SIZE	ISO	U	Ø V	Ø W	X	Y	Z	AA	BB	CC	DD	EE (GAS)	FF	GG	HH	JJ	KK	LL	MM
2	F03	30,0	25,0	16,0	20,0	4,5	11,5	2,0	4,0	M5	M6	1/8	12,0	8,0	5,0	12,0	24,0	16,0	32,0
4	F04	30,0	31,0	20,0	20,0	4,5	11,5	2,0	4,0	M5	M6	1/8	12,0	8,0	5,0	12,0	24,0	16,0	32,0
8	F05-F07	30,0	35,0	20,0	20,0	5,0	11,5	3,0	4,0	M5	M6	1/8	12,0	8,0	5,0	12,0	24,0	16,0	32,0
12	F07-F05	30,0	45,0	20,0	20,0	5,5	11,5	3,0	4,0	M5	M6	1/4	12,0	8,0	5,0	12,0	24,0	16,0	32,0
20	F07-F10	30,0	50,0	32,0	20,0	6,5	19,0	3,0	4,0	M5	M6	1/4	12,0	8,0	5,0	12,0	24,0	16,0	32,0
35	F10-F07	30,0	61,0	32,0	20,0	7,0	19,0	3,0	4,0	M5	M6	1/4	12,0	8,0	5,0	12,0	24,0	16,0	32,0
55	F12-F10	30,0	61,0	40,0	30,0	7,5	25,4	3,0	4,0	M5	M6	1/4	12,0	8,0	5,0	12,0	24,0	16,0	32,0
70	F12-F10	30,0	72,0	40,0	30,0	7,0	25,4	3,0	4,0	M5	M6	1/4	12,0	8,0	5,0	12,0	24,0	16,0	32,0
100	F14	30,0	78,0	40,0	30,0	7,0	25,4	4,0	4,0	M5	M6	1/4	12,0	8,0	5,0	12,0	24,0	16,0	32,0
150	F14	30,0	78,0	40,0	30,0	7,0	25,4	4,0	4,0	M5	M6	1/4	12,0	8,0	5,0	12,0	24,0	16,0	32,0



C-TYPE ACTUATOR DIMENSIONS – 2 - 150 –

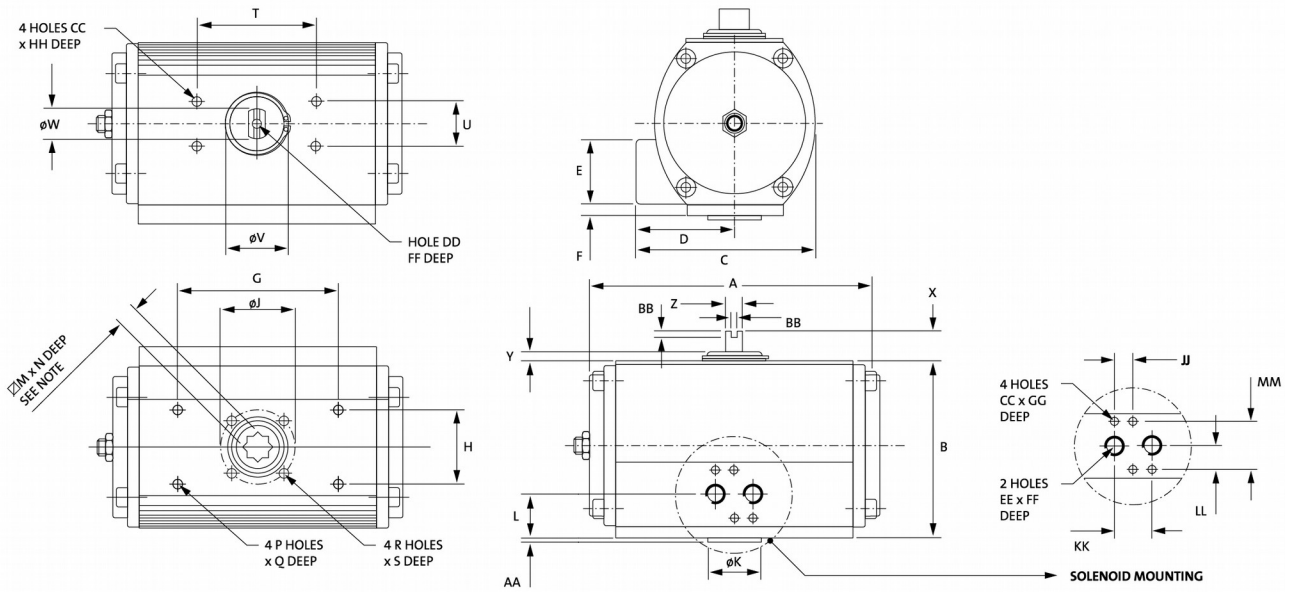

- Double Acting (DA) and Spring Return (SR)

- Single End Stop Adjustment – size 2 – 35 One Side – size 55 – 150 Both Sides

Dimensions Imperial (inches)

SIZE	ISO	A	B	C	D	E	F	G	H	ØJ	ØK	L	M	N	P (UNC)	Q	R (UNC)	S	T
2	F03	4,51	2,87	2,97	1,71	1,61	-	2,87	1,26	1,42	0,98	0,81	0,35	0,39	10-24	0,31	10-24	0,31	3,15
4	F04	5,24	3,56	3,44	1,87	1,61	-	2,87	1,26	1,65	1,18	0,81	0,43	0,47	10-24	0,31	10-24	0,31	3,15
8	F05-F07	6,38	4,29	4,13	2,24	1,65	0,30	2,87	1,26	1,97	1,38	1,12	0,55	0,63	1/4	0,39	1/4	0,39	3,15
12	F07-F05	7,64	4,67	4,76	2,64	1,69	0,31	4,21	1,93	2,76	1,38	1,16	0,67	0,63	1/4	0,39	5/16	0,39	3,15
20	F07-F10	8,58	5,53	5,37	2,83	1,69	0,31	4,21	1,93	2,76	2,17	1,16	0,67	0,75	1/4	0,39	5/16	0,51	3,15
35	F10-F07	10,47	6,56	6,14	3,07	1,69	0,33	6,34	2,87	4,02	2,76	1,18	0,87	0,94	1/4	0,47	3/8	0,63	3,15
55	F12-F10	12,28	8,17	7,52	3,76	1,69	0,81	6,34	2,87	4,92	3,35	1,65	1,06	1,14	5/16	0,59	1/2	0,79	5,12
70	F12-F10	13,39	8,17	7,52	3,76	1,69	0,81	8,39	4,02	4,92	3,35	1,65	1,06	1,14	5/16	0,47	1/2	0,79	5,12
100	F14	14,21	9,84	8,94	4,47	1,69	1,56	8,39	4,02	5,51	3,94	2,40	1,42	1,50	3/8	0,59	3/4	0,98	5,12
150	F14	15,35	11,81	11,02	5,51	1,69	2,22	9,61	4,61	5,51	3,94	3,07	1,42	1,50	1/2	0,87	3/4	0,98	5,12

SIZE	ISO	U	ØV	ØW	X	Y	Z	AA	BB	CC (UNF)	DD	EE (NPT)	FF	GG	HH	JJ	KK	LL	MM
2	F03	1,18	0,98	0,63	0,79	0,18	0,45	0,08	0,16	10-32	M6	1/8	0,47	0,31	0,20	0,47	0,94	0,63	1,26
4	F04	1,18	1,22	0,79	0,79	0,18	0,45	0,08	0,16	10-32	M6	1/8	0,47	0,31	0,20	0,47	0,94	0,63	1,26
8	F05-F07	1,18	1,38	0,79	0,79	0,20	0,45	0,12	0,16	10-32	M6	1/8	0,47	0,31	0,20	0,47	0,94	0,63	1,26
12	F07-F05	1,18	1,77	0,79	0,79	0,22	0,45	0,12	0,16	10-32	M6	1/4	0,47	0,31	0,20	0,47	0,94	0,63	1,26
20	F07-F10	1,18	1,97	1,26	0,79	0,26	0,75	0,12	0,16	10-32	M6	1/4	0,47	0,31	0,20	0,47	0,94	0,63	1,26
35	F10-F07	1,18	2,40	1,26	0,79	0,28	0,75	0,12	0,16	10-32	M6	1/4	0,47	0,31	0,20	0,47	0,94	0,63	1,26
55	F12-F10	1,18	2,40	1,57	1,18	0,30	1,00	0,12	0,16	10-32	M6	1/4	0,47	0,31	0,20	0,47	0,94	0,63	1,26
70	F12-F10	1,18	2,83	1,57	1,18	0,28	1,00	0,12	0,16	10-32	M6	1/4	0,47	0,31	0,20	0,47	0,94	0,63	1,26
100	F14	1,18	3,07	1,57	1,18	0,28	1,00	0,16	0,16	10-32	M6	1/4	0,47	0,31	0,20	0,47	0,94	0,63	1,26
150	F14	1,18	3,07	1,57	1,18	0,28	1,00	0,16	0,16	10-32	M6	1/4	0,47	0,31	0,20	0,47	0,94	0,63	1,26



C-TYPE ACTUATOR PART LIST – 250 –

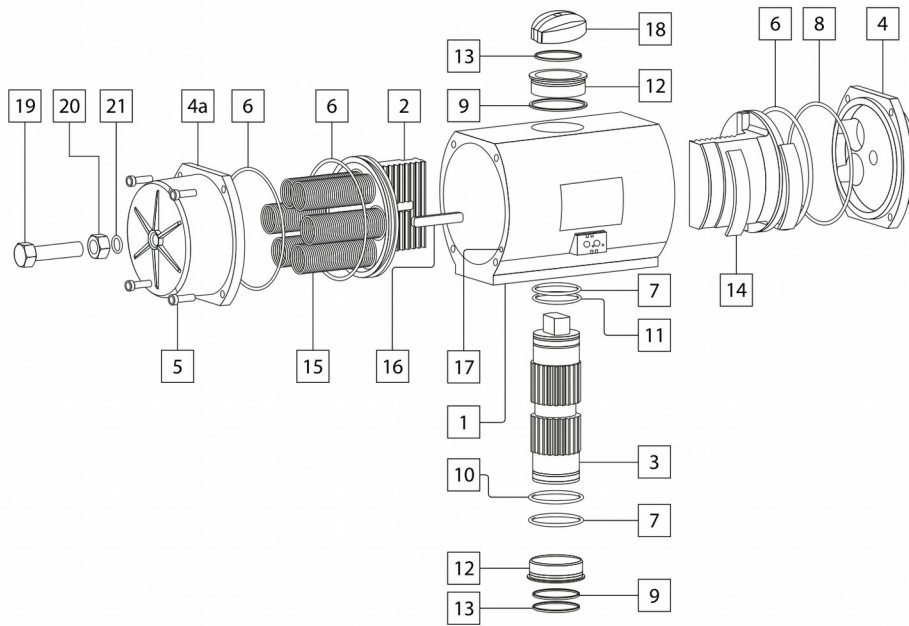

Ref. No	Description	Quantity	Material	
			Standard	CNI®
1	Body	1	Aluminum, Anodized	Aluminum, CNI® treated
2	Pistons	2	Aluminum	Aluminum, Anodized
3	Driveshaft	1	Steel, Zinkplated	Steel, Nickelplated + Teflon
4	Endcap, DA	2	Aluminum, Polyester Coated	Aluminum, CNI® treated
4 a	Endcap, SR	2	Aluminum, Polyester Coated	Aluminum, CNI® treated
5	Endcap Bolt	8	Stainless Steel	Stainless Steel
6	Piston O-ring	2	NBR	NBR
7	Driveshaft O-ring	2	NBR	NBR
8	Endcap O-ring	2	NBR	NBR
9	Driveshaft Washer	2	POM	POM
10 – 11	Bushing Outer O-ring	2	NBR	NBR
12	Bushing	2	Bronze	Bronze
13	Circlip	2	Steel, Nickelplated	Steel, Nickelplated
14	Wearpad	4	POM	POM
15	Spring	Max 12	SiCr	SiCr
16	Guidebar	2	Steel	Steel
17	Ball Seal	2	NBR	NBR
18	Position Indicator	1	POM	POM
19	Stop Adjustment Screw	2	Stainless Steel	Stainless Steel
20	Stop Adjustment Nut	2	Stainless Steel	Stainless Steel
21	Stop Adjustment O-ring	2	Stainless Steel	Stainless Steel
	Stop Adjustment Washer	2	Stainless Steel	Stainless Steel



C-TYPE ACTUATOR PART LIST – 400 –

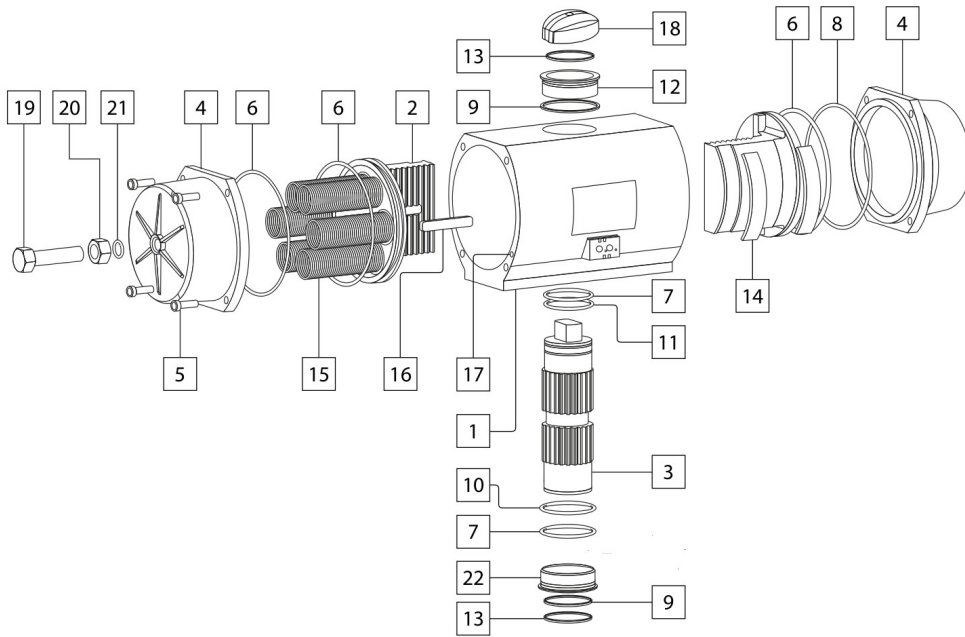

Ref. No	Description	Quantity	Material	
			Standard	CNI®
1	Body	1	Aluminum, Anodized	Aluminum, CNI® treated
2	Pistons	2	Aluminum	Aluminum, Anodized
3	Driveshaft	1	Steel, Zinkplated	Steel, Nickelplated + Teflon
4	Endcap, DA	2	Aluminum, Polyester Coated	Aluminum, CNI® treated
5	Endcap Bolt	16	Stainless Steel	Stainless Steel
6	Piston O-ring	2	NBR	NBR
7	Bushing Outer O-ring	2	NBR	NBR
8	Endcap O-ring	2	NBR	NBR
9	Driveshaft Washer	2	POM	POM
10	Lower Bushing Inner O-ring	1	NBR	NBR
11	Driveshaft O-ring	1	NBR	NBR
12	Upper Bushing	1	Bronze	Bronze
13	Circlip	2	Steel, Nickelplated	Steel, Nickelplated
14	Wearpad	4	POM	POM
15	Spring	Max 16	SiCr	SiCr
16	Guidebar	2	Steel	Steel
17	Ball Seal	2	NBR	NBR
18	Position Indicator	1	POM	POM
19	Stop Adjustment Screw	2	Stainless Steel	Stainless Steel
20	Stop Adjustment Nut	2	Stainless Steel	Stainless Steel
21	Stop Adjustment O-ring	2	Stainless Steel	Stainless Steel
	Stop Adjustment Washer	2	Stainless Steel	Stainless Steel
22	Lower Bushing	1	Bronze	Bronze



C-TYPE ACTUATOR DIMENSIONS – 250 - 400 –

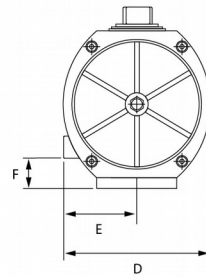
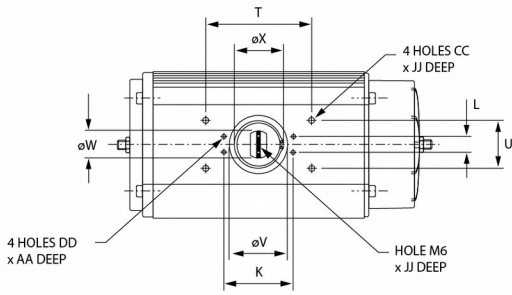

- Double Acting (DA) and Spring Return (SR)
- Single End Stop Adjustment Both Sides

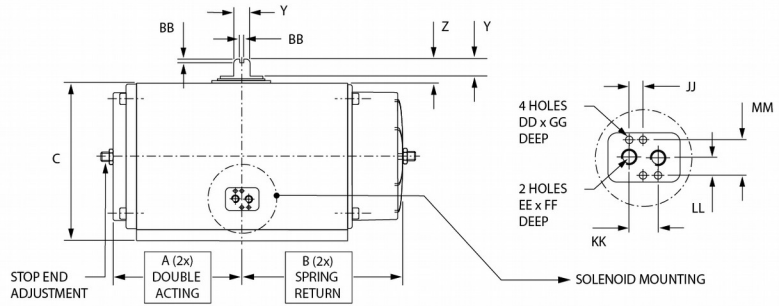
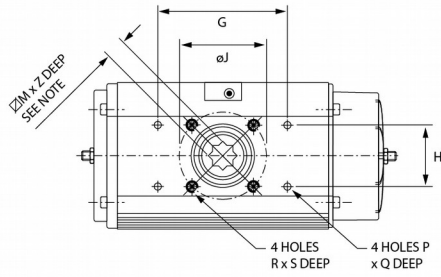

Dimensions Metric (mm)

SIZE	ISO	A	B	C	D	E	F	G	H	ØJ	ØK	L	M	P	Q	R	S	T
250	F16	248,0	338,0	300,0	280,0	140,0	56,0	244,0	117,0	166,0	130,0	30,0	46,0	M12	22,0	M20	32,0	200,0

SIZE	ISO	U	ØV	ØW	ØX	Y	Z	AA	BB	CC	DD	EE (GAS)	FF	GG	JJ	KK	LL	MM
250	F16	90,0	120,0	60,0	111,0	36,0	50,0	6,0	4,0	M8	M5	1/4	12,0	8,0	12,0	24,0	16,0	32,0

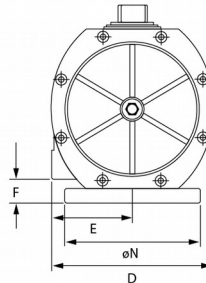
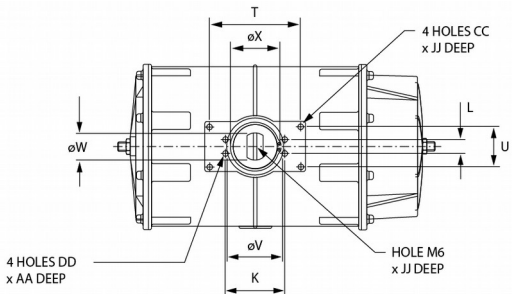

- Double Acting (DA) and Spring Return (SR)
- Single End Stop Adjustment Both Sides

NOTE!
Older version had different End Caps for DA and SR. Later versions are delivered with the type of End Caps specified for SR Actuators.

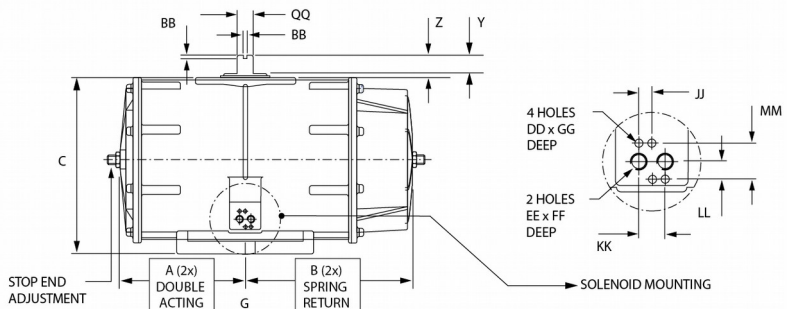
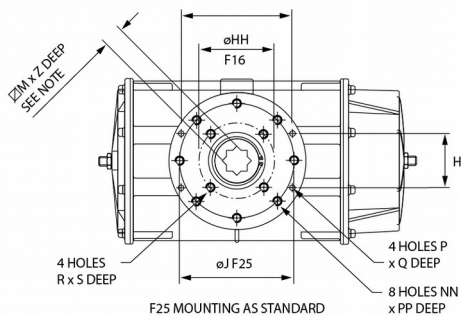

Dimensions Metric (mm)

SIZE	ISO	A	B	C	D	E	F	G	ØJ	K	L	M	ØN	P	Q	R	S	T	U	ØV
400	F16 – F25	300,0	371,0	385,0	360,0	180,0	53,0	244,0	254,0	130,0	30,0	55,0	300,0	M12	22,0	M20	35,0	200,0	90,0	120,0

SIZE	ISO	ØW	ØX	Y	Z	AA	BB	CC	DD	EE (GAS)	FF	GG	ØHH	JJ	KK	LL	MM	NN	PP	QQ
400	F16 – F25	60,0	111,0	40,0	60,0	9,0	4,0	M8	M5	1/4	12,0	8,0	166,0	12,0	24,0	16,0	32,0	M16	25,0	36,0



C-TYPE ACTUATOR DIMENSIONS – 250 - 400 –

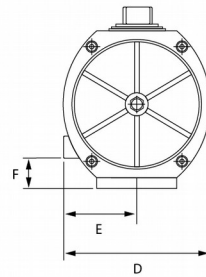
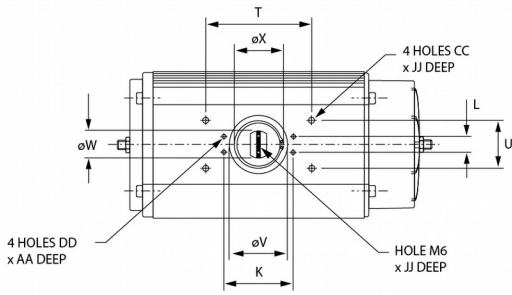

- Double Acting (DA) and Spring Return (SR)
- Single End Stop Adjustment Both Sides

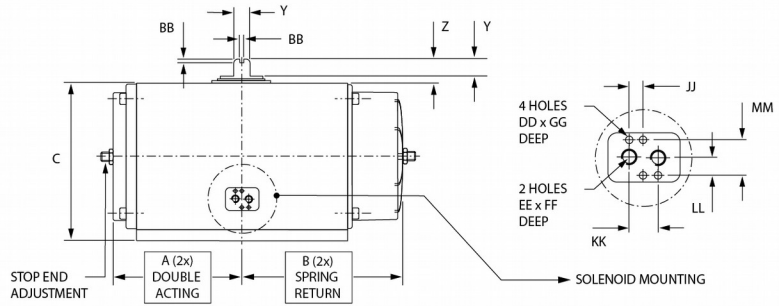
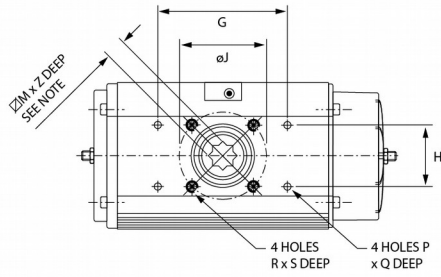

Dimensions Imperial (inches)

SIZE	ISO	A	B	C	D	E	F	G	H	ØJ	ØK	L	M	P (UNC)	Q	R (UNC)	S	T
250	F16	9,76	13,31	11,81	11,02	5,51	2,20	9,61	4,61	6,54	5,12	1,18	1,81	1/2	0,87	3/4	1,26	7,87

SIZE	ISO	U	ØV	ØW	ØX	Y	Z	AA	BB	CC (UNC)	DD (UNF)	EE (NPT)	FF	GG	JJ	KK	LL	MM
250	F16	3,54	4,72	2,36	4,37	1,42	1,97	0,24	0,16	5/16	10-32	1/4	0,47	0,31	0,47	0,94	0,63	1,26

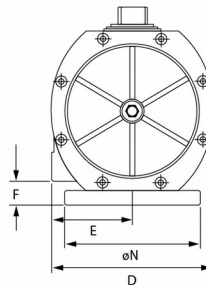
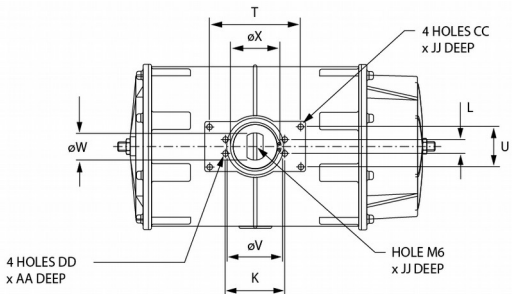

- Double Acting (DA) and Spring Return (SR)
- Single End Stop Adjustment Both Sides

NOTE!

Older version had different End Caps for DA and SR. Later versions are delivered with the type of End Caps specified for SR Actuators.

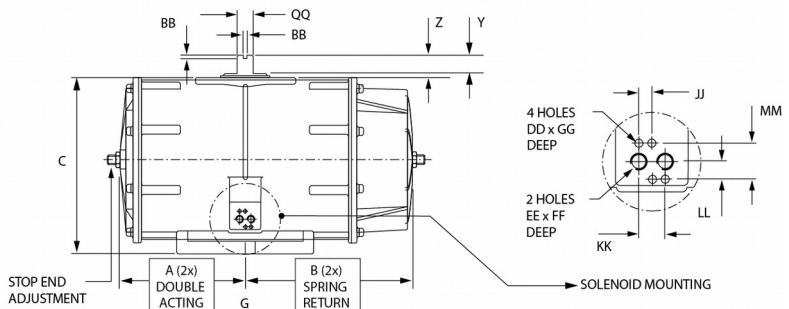
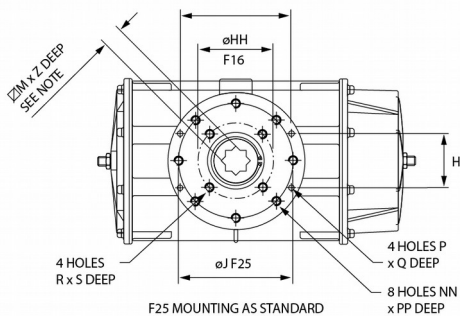

Dimensions Imperial (inches)

SIZE	ISO	A	B	C	D	E	F	G	ØJ	K	L	M	ØN	P (UNC)	Q	R (UNC)	S	T	U	ØV
400	F16-F25	11,81	14,61	15,16	14,17	7,09	2,09	9,61	10,00	5,12	1,18	2,17	11,81	1/2	0,87	3/4	1,38	7,87	3,54	4,72

SIZE	ISO	ØW	ØX	Y	Z	AA	BB	CC (UNC)	DD (UNF)	EE (NPT)	FF	GG	ØHH	JJ	KK	LL	MM	NN (UNC)	PP	QQ
400	F16-F25	2,36	4,37	1,57	2,36	0,35	0,16	5/16	10-32	1/4	0,47	0,31	6,54	0,47	0,94	0,63	1,26	5/8	0,98	1,42



180° C-TYPE ACTUATOR PART LIST – 2 - 35 –

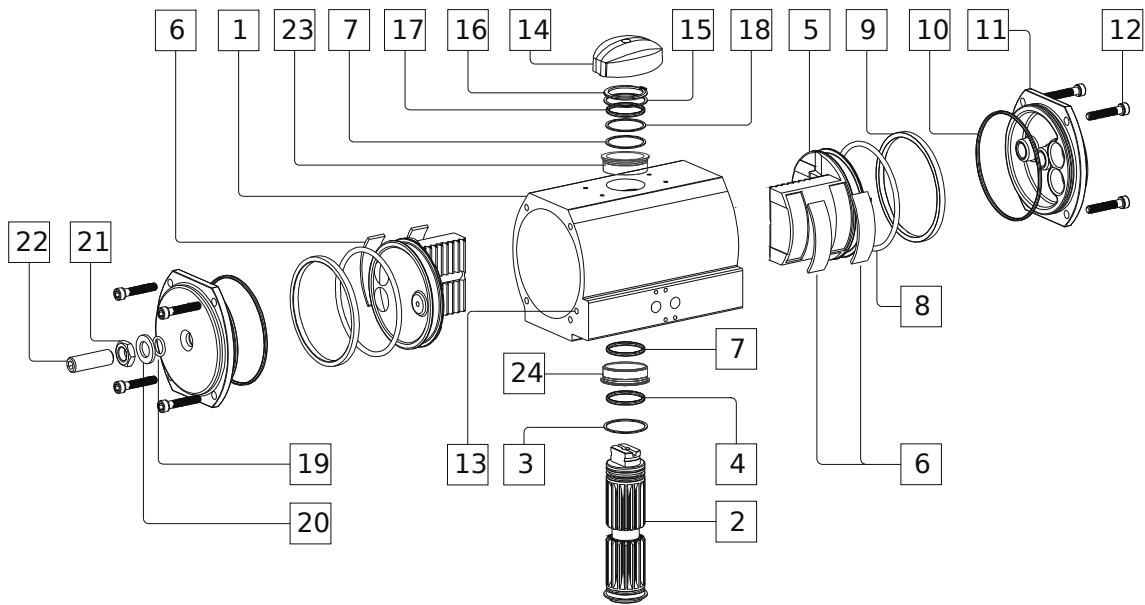

Ref. No	Description	Quantity	Material	
			Standard	CNI®
1	Body	1	Aluminum, Anodized	Aluminum, CNI® treated
2	Driveshaft	1	Steel, Zinkplated	Steel, Nickelplated + Teflon
3	Driveshaft Lower Washer	1	POM	POM
4	Driveshaft Lower O-ring	1	NBR	NBR
5	Piston	2	Aluminum	Aluminum, Anodized
6	Wearpad	4	POM	POM
7	Bushing O-ring	2	NBR	NBR
8	Piston O-ring	2	NBR	NBR
9	Piston Back-up Bearing	2	POM	POM
10	Endcap O-ring	2	NBR	NBR
11	Endcap Plain + Endcap with Adjustment	1 + 1	Aluminum, Polyester Coated	Aluminum, CNI® treated
12	Endcap Bolt	8	Stainless Steel	Stainless Steel
13	Ball Seal	2	NBR	NBR
14	Position Indicator	1	POM	POM
15	Driveshaft Upper Washer	1	POM	POM
16	Driveshaft Circlip	1	Steel, Nickelplated	Steel, Nickelplated
17	Driveshaft Upper Bearing	1	POM	POM
18	Driveshaft Upper O-ring	1	NBR	NBR
19	Stop Adjustment O-ring	1	Stainless Steel	Stainless Steel
20	Stop Adjustment Washer	1	Stainless Steel	Stainless Steel
21	Stop Adjustment Nut	1	Stainless Steel	Stainless Steel
22	Stop Adjustment Screw	1	Stainless Steel	Stainless Steel
23	Upper Bushing	1	POM	Bronze
24	Lower Bushing	1	POM	Bronze



180° C-TYPE ACTUATOR METRIC DIMENSIONS – 2 - 35 –

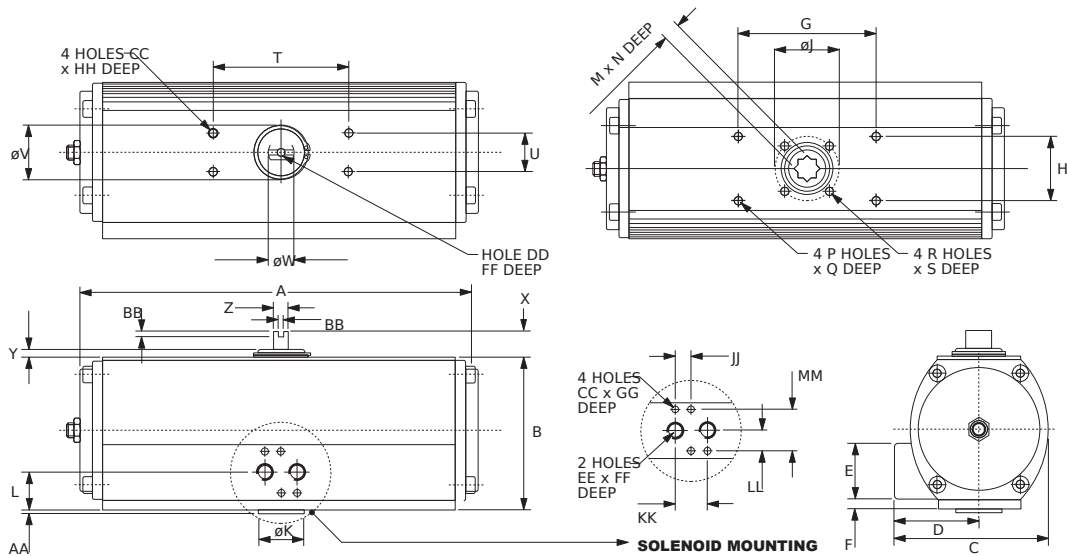

- Double Acting (DA) - Single End Stop Adjustment

Dimensions Metric (mm)

SIZE	ISO	A	B	C	D	E	F	G	H	ØJ	ØK	L	M	N	P	Q	R	S	T
2	F03	169,0	73,0	75,5	43,5	41,0	-	73,0	32,0	36,0	25,0	20,5	9,0	10,0	M5	8,0	M5	8,0	80,0
4	F04	133,0	90,5	87,5	47,5	41,0	-	73,0	32,0	42,0	30,0	20,5	11,0	12,0	M5	8,0	M5	8,0	80,0
8	F05	162,0	109,0	105,0	57,0	42,0	7,5	73,0	32,0	50,0	35,0	28,5	14,0	16,0	M6	10,0	M6	10,0	80,0
12	F07	194,0	118,5	121,0	67,0	43,0	8,0	107,0	49,0	50,0	55,0	29,5	17,0	16,0	M6	10,0	M8	10,0	80,0
20	F07	218,0	140,5	136,5	72,0	43,0	8,0	107,0	49,0	70,0	55,0	29,5	17,0	19,0	M6	13,0	M8	13,0	80,0
35	F10	266,0	166,5	156,0	78,0	43,0	8,5	161,0	73,0	102,0	70,0	30,0	22,0	24,0	M8	16,0	M10	16,0	80,0

SIZE	ISO	U	ØV	ØW	X	Y	Z	AA	BB	CC	DD	EE (GAS)	FF	GG	HH	JJ	KK	LL	MM
2	F03	30,0	25,0	16,0	20,0	4,5	11,5	2,0	4,0	M5	M6	1/8	12,0	8,0	5,0	12,0	24,0	16,0	32,0
4	F04	30,0	31,0	20,0	20,0	4,5	11,5	2,0	4,0	M5	M6	1/8	12,0	8,0	5,0	12,0	24,0	16,0	32,0
8	F05	30,0	35,0	20,0	20,0	5,0	11,5	3,0	4,0	M5	M6	1/8	12,0	8,0	5,0	12,0	24,0	16,0	32,0
12	F07	30,0	45,0	20,0	20,0	5,5	11,5	3,0	4,0	M5	M6	1/4	12,0	8,0	5,0	12,0	24,0	16,0	32,0
20	F07	30,0	50,0	32,0	20,0	6,5	19,0	3,0	4,0	M5	M6	1/4	12,0	8,0	5,0	12,0	24,0	16,0	32,0
35	F10	30,0	61,0	32,0	20,0	7,0	19,0	3,0	4,0	M5	M6	1/4	12,0	8,0	5,0	12,0	24,0	16,0	32,0

Dimensions Imperial (inches)

SIZE	ISO	A	B	C	D	E	F	G	H	ØJ	ØK	L	M	N	P (UNC)	Q	R (UNC)	S	T
2	F03	6,65	2,87	2,97	1,71	1,61	-	2,87	1,26	1,42	0,98	0,81	0,35	0,39	10-24	0,31	10-24	0,31	3,15
4	F04	5,24	3,56	3,44	1,87	1,61	-	2,87	1,26	1,65	1,18	0,81	0,43	0,47	10-24	0,31	10-24	0,31	3,15
8	F05	6,38	4,29	4,13	2,24	1,65	0,30	2,87	1,26	1,97	1,38	1,12	0,55	0,63	1/4	0,39	1/4	0,39	3,15
12	F07	7,64	4,67	4,76	2,64	1,69	0,31	4,21	1,93	1,97	2,17	1,16	0,67	0,63	1/4	0,39	5/16	0,39	3,15
20	F07	8,58	5,53	5,37	2,83	1,69	0,31	4,21	1,93	2,76	2,17	1,16	0,67	0,75	1/4	0,51	5/16	0,51	3,15
35	F10	10,47	6,56	6,14	3,07	1,69	0,33	6,34	2,87	4,02	2,76	1,18	0,87	0,94	5/16	0,63	1/2	0,63	3,15

SIZE	ISO	U	ØV	ØW	X	Y	Z	AA	BB	CC (UNF)	DD	EE (NPT)	FF	GG	HH	JJ	KK	LL	MM
2	F03	1,18	0,98	0,63	0,79	0,18	0,45	0,08	0,16	10-32	M6	1/8	0,47	0,31	0,20	0,47	0,94	0,63	1,26
4	F04	1,18	1,22	0,79	0,79	0,18	0,45	0,08	0,16	10-32	M6	1/8	0,47	0,31	0,20	0,47	0,94	0,63	1,26
8	F05	1,18	1,38	0,79	0,79	0,20	0,45	0,12	0,16	10-32	M6	1/8	0,47	0,31	0,20	0,47	0,94	0,63	1,26
12	F07	1,18	1,77	0,79	0,79	0,22	0,45	0,12	0,16	10-32	M6	1/4	0,47	0,31	0,20	0,47	0,94	0,63	1,26
20	F07	1,18	1,97	1,26	0,79	0,26	0,75	0,12	0,16	10-32	M6	1/4	0,47	0,31	0,20	0,47	0,94	0,63	1,26
35	F10	1,18	2,40	1,26	0,79	0,28	0,75	0,12	0,16	10-32	M6	1/4	0,47	0,31	0,20	0,47	0,94	0,63	1,26



E-TYPE ACTUATOR BENEFIT

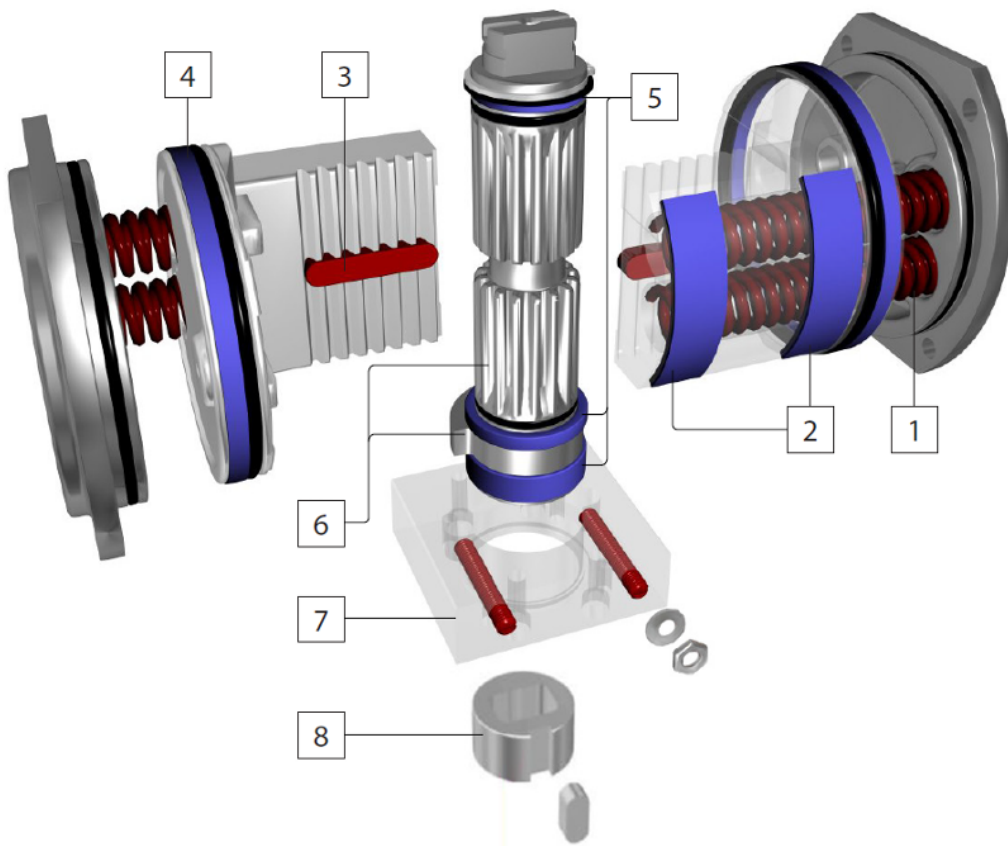

1. SPRINGS

- Springs are located inside the piston rack, same overall dimensions for DA and SR actuators
- No special tools required to change from DA to SR or opposite
- Long bolting is standard feature to fully relax springs

2. PISTON WEAR PADS

- Dual encapsulated "POM" wear pads on the piston, prevent metal to metal contact between piston and cylinder, thus providing low friction travel
- The dual encapsulated "POM" wear pads absorb the adverse side loading at start of each stroke

3. TWIN GUIDE BARS

- Twin guide bars absorb any adverse side loading, from rack at the start of each stroke, which reduces pinion and rack wear

4. BACKUP BEARING

- Piston backup bearings, which are situated behind the pistons o-ring, ensure linear movement and prevent wear on the cylinder surface

5. TRIPLE SHAFT BEARING

- Triple shaft bearing to prevent any adverse loading on the driveshaft

6. DRIVESHAFT & CAM

- The shaft and adjustment cam are machined from solid bar material
- The cam mechanism allows for 2.5° overtravel in both directions
- The inner depth of the driveshaft allows for total engagement of any valve shaft height for direct mounting

7. BODY ADAPTOR KIT

- Integral Body Adaptor Kit (BAK), interchangeable with a wide range of valves for direct mounting by using an interchangeable sleeve
- Dual End Stop Adjustment are integral to the body adaptor and operate in conjunction with the machined cam on a single piece driveshaft, remaining outside the pressurized cylinder

8. INSERT SLEEVE

- Manufacture in stainless steel, can be rotated for cross or parallel mounting.
- The insert is held inside the driveshaft by means of a circlip
- Can be Square, Double D or Round with Key for direct mounting



E-TYPE ACTUATOR PART LIST – 8 - 150 –

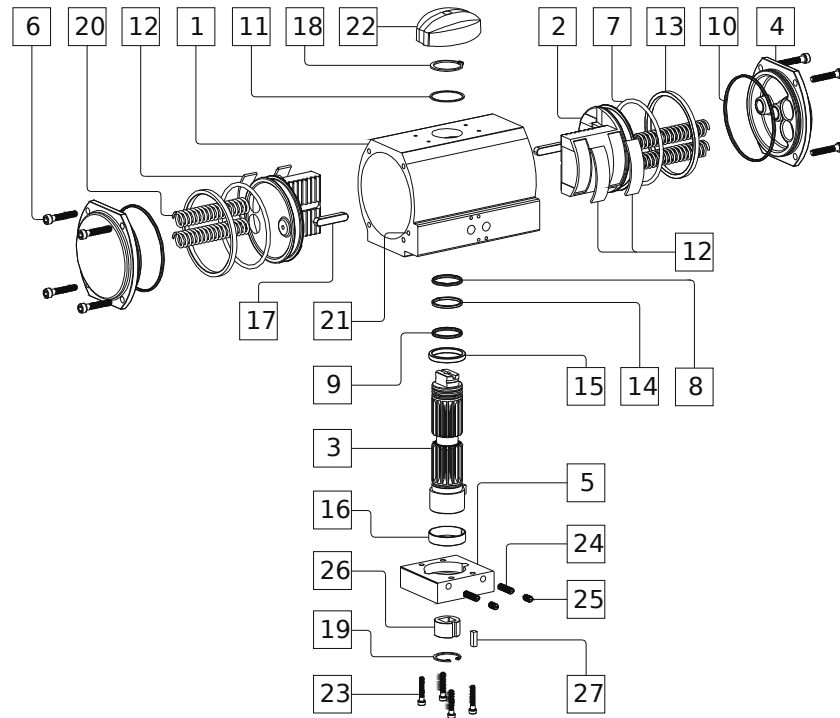

Ref. No	Description	Quantity	Material	
			Standard	CNI®
1	Body	1	Aluminum, Anodized	Aluminum, CNI® treated
2	Piston	2	Aluminum	Aluminum, Anodized
3	Driveshaft	1	Steel, Zinkplated	Steel, Nickelplated + Teflon
4	Endcap	2	Aluminum, Polyester Coated	Aluminum, CNI® treated
5	Body Adaptor	1	Aluminum, Anodized	Aluminum, CNI® treated
6	Endcap Bolt	8	Stainless Steel	Stainless Steel
7	Piston O-ring	2	NBR	NBR
8	Driveshaft Upper O-ring	1	NBR	NBR
9	Driveshaft Lower O-ring	1	NBR	NBR
10	Endcap O-ring	2	NBR	NBR
11	Washer	1	POM	POM
12	Wearpad	4	POM	POM
13	Piston Back-up Bearing	2	POM	POM
14	Driveshaft Upper Bearing	1	POM	POM
15	Driveshaft Lower Bearing	1	POM	POM
16	Body Adaptor Bearing	1	POM	POM
17	Guide Bar	2	Steel	Steel
18	Driveshaft Circlip	1	Steel, Nickelplated	Steel, Nickelplated
19	Body Adaptor Circlip	1	Steel, Nickelplated	Steel, Nickelplated
20	Spring (Outer/Inner)	Max 4/4	SiCr	SiCr
21	Ball Seal	2	NBR	NBR
22	Position Indicator	1	POM	POM
23	Body Adaptor Bolts	4	Stainless Steel	Stainless Steel
24	Stop Adjustment Screws	2	Stainless Steel	Stainless Steel
25	Stop Adjustment Nuts	2	Stainless Steel	Stainless Steel
26	Insert	1	Stainless Steel	Stainless Steel
27	Insert Sleeve Key	1	Stainless Steel	Stainless Steel



E-TYPE ACTUATOR DIMENSIONS – 8 - 150 –

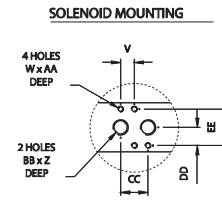
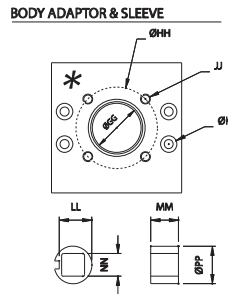
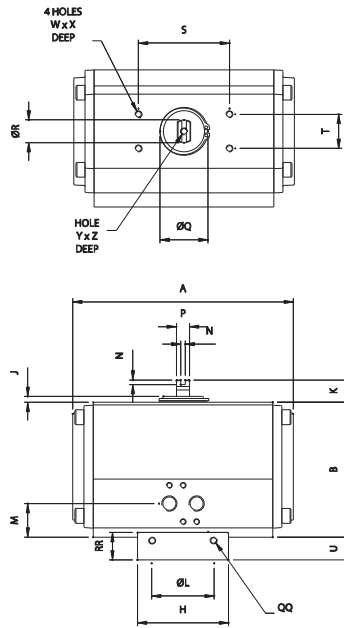

* Body Adaptor may be dual drilled

- Double Acting (DA) and Spring Return (SR)
- Double End Stop Adjustment

Dimensions Metric (mm)

SIZE	ISO	A	B	C	D	E	F	G	H	J	K	ØL	M	N	P	ØQ	ØR	S	T	U	V
8	F05	162,0	109,0	105,0	57,0	42,0	7,5	127,0	80,0	5,0	20,0	35,0	27,0	4,0	11,5	35,0	20,0	80,0	30,0	18,0	12,0
8	F07	162,0	109,0	105,0	57,0	42,0	7,5	127,0	80,0	5,0	20,0	35,0	27,0	4,0	11,5	35,0	20,0	80,0	30,0	18,0	12,0
12	F05	194,0	118,5	121,0	67,0	43,0	8,0	138,5	80,0	5,5	20,0	35,0	29,5	4,0	11,5	46,0	20,0	80,0	30,0	20,0	12,0
12	F07	194,0	118,5	121,0	67,0	43,0	8,0	138,5	80,0	5,5	20,0	35,0	29,5	4,0	11,5	46,0	20,0	80,0	30,0	20,0	12,0
20	F07	218,0	140,5	136,5	72,0	43,0	8,0	164,5	90,0	6,5	20,0	55,0	29,5	4,0	19,0	50,0	32,0	80,0	30,0	24,0	12,0
35	F07	266,0	166,5	156,0	78,0	43,0	8,5	196,7	120,0	7,0	30,0	55,0	30,0	4,0	19,0	61,0	32,0	80,0	30,0	30,2	12,0
35	F10	266,0	166,5	156,0	78,0	43,0	8,5	196,7	120,0	7,0	30,0	55,0	30,0	4,0	19,0	61,0	32,0	80,0	30,0	30,2	12,0
55	F10	312,0	207,5	191,0	95,5	43,0	20,5	242,5	140,0	7,5	30,0	85,0	42,0	4,0	25,4	61,0	40,0	130,0	30,0	35,0	12,0
55	F12	312,0	207,5	191,0	95,5	43,0	20,5	242,5	140,0	7,5	30,0	85,0	42,0	4,0	25,4	61,0	40,0	130,0	30,0	35,0	12,0
70	F10	340,0	211,0	191,0	95,5	43,0	20,5	247,0	140,0	7,0	30,0	85,0	42,0	4,0	25,4	72,0	40,0	130,0	30,0	36,0	12,0
70	F12	340,0	211,0	191,0	95,5	43,0	20,5	247,0	140,0	7,0	30,0	85,0	42,0	4,0	25,4	72,0	40,0	130,0	30,0	36,0	12,0
100	F14	361,0	253,3	227,0	113,5	43,0	39,5	303,0	160,0	7,0	30,0	100,1	61,0	4,0	25,4	78,0	40,0	130,0	30,0	49,8	12,0
150	F14	390,0	302,0	280,0	140,0	43,0	56,5	351,0	160,0	7,0	30,0	100,1	78,0	4,0	25,4	78,0	40,0	130,0	30,0	49,0	12,0

SIZE	ISO	W	X	Y	Z	AA	BB (GAS)	CC	DD	EE	FF	ØGG	ØHH	JJ	ØKK	LL	MM	NN	ØPP	QQ	RR
8	F05	M5	5,0	M6	12,0	8,0	1/8	24,0	16,0	32,0	79,0	30,0	50,0	M6	5,5	20,0	17,0	14,0	23,0	M5	22,0
8	F07	M5	5,0	M6	12,0	8,0	1/8	24,0	16,0	32,0	79,0	47,0	70,0	M8	5,5	29,5	17,0	17,0	33,0	M6	24,0
12	F05	M5	5,0	M6	12,0	8,0	1/4	24,0	16,0	32,0	79,0	30,0	50,0	M6	5,5	20,0	17,0	14,0	23,0	M6	22,0
12	F07	M5	5,0	M6	12,0	8,0	1/4	24,0	16,0	32,0	79,0	47,0	70,0	M8	5,5	29,5	17,0	17,0	33,0	M6	24,0
20	F07	M5	5,0	M6	12,0	8,0	1/4	24,0	16,0	32,0	89,9	46,0	70,0	M8	6,6	29,5	20,0	17,0	33,0	M8	28,0
35	F07	M5	5,0	M6	12,0	8,0	1/4	24,0	16,0	32,0	119,9	46,0	70,0	M8	9,0	29,5	20,0	17,0	33,0	M10	34,0
35	F10	M5	5,0	M6	12,0	8,0	1/4	24,0	16,0	32,0	119,9	61,0	102,0	M10	9,0	39,0	25,0	22,0	44,0	M10	34,0
55	F10	M5	5,0	M6	12,0	8,0	1/4	24,0	16,0	32,0	139,9	61,0	102,0	M10	11,0	39,0	25,0	22,0	44,0	M10	40,0
55	F12	M5	5,0	M6	12,0	8,0	1/4	24,0	16,0	32,0	139,9	75,0	125,0	M12	11,0	50,0	25,0	27,0	55,0	M10	40,0
70	F10	M5	5,0	M6	12,0	8,0	1/4	24,0	16,0	32,0	139,9	61,0	102,0	M10	11,0	39,0	25,0	22,0	44,0	M10	40,0
70	F12	M5	5,0	M6	12,0	8,0	1/4	24,0	16,0	32,0	139,9	75,0	125,0	M12	11,0	50,0	25,0	27,0	55,0	M10	40,0
100	F14	M5	5,0	M6	12,0	8,0	1/4	24,0	16,0	32,0	159,9	88,0	140,0	M16	14,0	62,5	35,0	36,0	68,0	M14	57,0
150	F14	M5	5,0	M6	12,0	8,0	1/4	24,0	16,0	32,0	159,9	88,0	140,0	M16	14,0	62,5	35,0	36,0	68,0	M14	57,0



E-TYPE ACTUATOR DIMENSIONS – 8 - 150 –

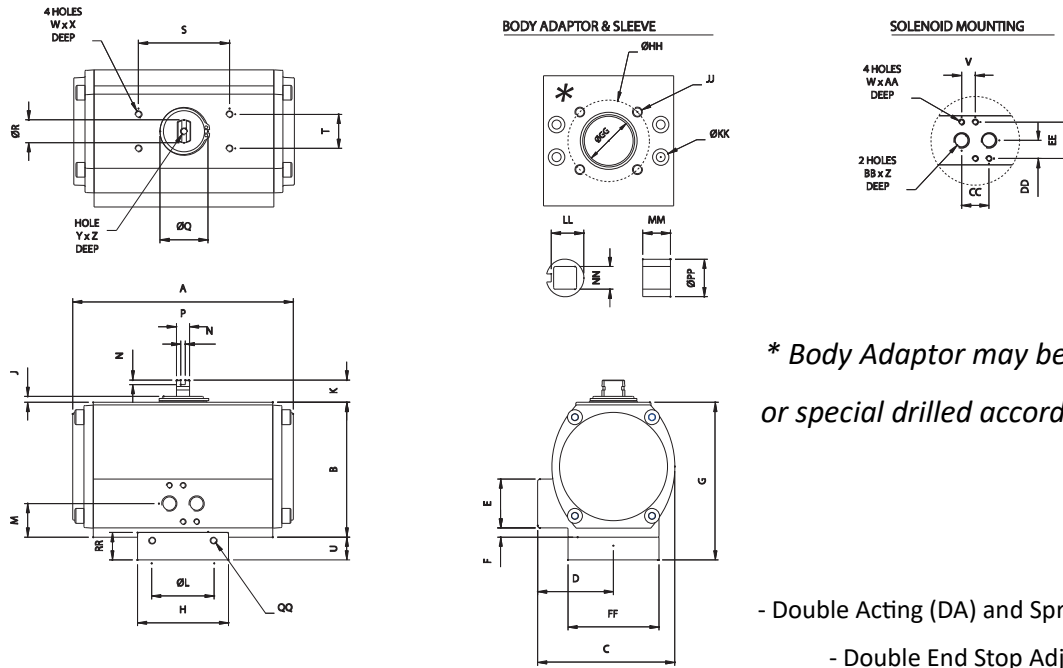

* Body Adaptor may be dual drilled or special drilled according to valve.

- Double Acting (DA) and Spring Return (SR)
- Double End Stop Adjustment

Dimensions Imperial (inches)

SIZE	ISO	A	B	C	D	E	F	G	H	J	K	ØL	M	N	P	ØQ	ØR	S	T	U	V
8	F05	6,38	4,29	4,13	2,24	1,65	0,30	5,00	3,15	0,20	0,79	1,38	1,06	0,16	0,45	1,38	0,79	3,15	1,18	0,71	0,47
8	F07	6,38	4,29	4,13	2,24	1,65	0,30	5,00	3,15	0,20	0,79	1,38	1,06	0,16	0,45	1,38	0,79	3,15	1,18	0,71	0,47
12	F05	7,64	4,67	4,76	2,64	1,69	0,31	5,45	3,15	0,22	0,79	1,38	1,16	0,16	0,45	1,81	0,79	3,15	1,18	0,79	0,47
12	F07	7,64	4,67	4,76	2,64	1,69	0,31	5,45	3,15	0,22	0,79	1,38	1,16	0,16	0,45	1,81	0,79	3,15	1,18	0,79	0,47
20	F07	8,58	5,53	5,37	2,83	1,69	0,31	6,48	3,54	0,26	0,79	2,17	1,16	0,16	0,75	1,97	1,26	3,15	1,18	0,94	0,47
35	F07	10,47	6,56	6,14	3,07	1,69	0,33	7,74	4,72	0,28	1,18	2,17	1,18	0,16	0,75	2,40	1,26	3,15	1,18	1,19	0,47
35	F10	10,47	6,56	6,14	3,07	1,69	0,33	7,74	4,72	0,28	1,18	2,17	1,18	0,16	0,75	2,40	1,26	3,15	1,18	1,19	0,47
55	F10	12,28	8,17	7,52	3,76	1,69	0,81	9,55	5,51	0,30	1,18	3,35	1,65	0,16	1,00	2,40	1,57	5,12	1,18	1,38	0,47
55	F12	12,28	8,17	7,52	3,76	1,69	0,81	9,55	5,51	0,30	1,18	3,35	1,65	0,16	1,00	2,40	1,57	5,12	1,18	1,38	0,47
70	F10	13,39	8,31	7,52	3,76	1,69	0,81	9,72	5,51	0,28	1,18	3,35	1,65	0,16	1,00	2,83	1,57	5,12	1,18	1,42	0,47
70	F12	13,39	8,31	7,52	3,76	1,69	0,81	9,72	5,51	0,28	1,18	3,35	1,65	0,16	1,00	2,83	1,57	5,12	1,18	1,42	0,47
100	F14	14,21	9,97	8,94	4,47	1,69	1,56	11,93	6,30	0,28	1,18	3,94	2,40	0,16	1,00	3,07	1,57	5,12	1,18	1,96	0,47
150	F14	15,35	11,89	11,02	5,51	1,69	2,22	13,82	6,30	0,28	1,18	3,94	3,07	0,16	1,00	3,07	1,57	5,12	1,18	1,93	0,47

SIZE	ISO	W (UNF)	X	Y	Z	AA	BB (NPT)	CC	DD	EE	FF	ØGG	ØHH	JJ (UNC)	ØKK	LL	MM	NN	ØPP	QQ	RR
8	F05	10-32	0,20	M6	0,47	0,31	1/8	0,94	0,63	1,26	3,11	1,18	1,97	1/4	0,22	0,79	0,67	0,55	0,91	M5	0,87
8	F07	10-32	0,20	M6	0,47	0,31	1/8	0,94	0,63	1,26	3,11	1,85	2,76	5/16	0,22	1,16	0,67	0,67	1,30	M6	0,94
12	F05	10-32	0,20	M6	0,47	0,31	1/4	0,94	0,63	1,26	3,11	1,18	1,97	1/4	0,22	0,79	0,67	0,55	0,91	M6	0,87
12	F07	10-32	0,20	M6	0,47	0,31	1/4	0,94	0,63	1,26	3,11	1,85	2,76	5/16	0,22	1,16	0,67	0,67	1,30	M6	0,94
20	F07	10-32	0,20	M6	0,47	0,31	1/4	0,94	0,63	1,26	3,54	1,81	2,76	5/16	0,26	1,16	0,79	0,67	1,30	M8	1,10
35	F07	10-32	0,20	M6	0,47	0,31	1/4	0,94	0,63	1,26	4,72	1,81	2,76	5/16	0,35	1,16	0,79	0,67	1,30	M10	1,34
35	F10	10-32	0,20	M6	0,47	0,31	1/4	0,94	0,63	1,26	4,72	2,40	4,02	3/8	0,35	1,54	0,98	0,87	1,73	M10	1,34
55	F10	10-32	0,20	M6	0,47	0,31	1/4	0,94	0,63	1,26	5,51	2,40	4,02	3/8	0,43	1,54	0,98	0,87	1,73	M10	1,57
55	F12	10-32	0,20	M6	0,47	0,31	1/4	0,94	0,63	1,26	5,51	2,95	4,92	1/2	0,43	1,97	0,98	1,06	2,17	M10	1,57
70	F10	10-32	0,20	M6	0,47	0,31	1/4	0,94	0,63	1,26	5,51	2,40	4,02	3/8	0,43	1,54	0,98	0,87	1,73	M10	1,57
70	F12	10-32	0,20	M6	0,47	0,31	1/4	0,94	0,63	1,26	5,51	2,95	4,92	1/2	0,43	1,97	0,98	1,06	2,17	M10	1,57
100	F14	10-32	0,20	M6	0,47	0,31	1/4	0,94	0,63	1,26	6,30	3,46	5,51	5/8	0,55	2,46	1,38	1,42	2,68	M14	2,24
150	F14	10-32	0,20	M6	0,47	0,31	1/4	0,94	0,63	1,26	6,30	3,46	5,51	5/8	0,55	2,46	1,38	1,42	2,68	M14	2,24



TECHNICAL DATA

OVERALL WEIGHT (kg)

SIZE	Double Acting "DA"	Spring Return "SR"
1	0,6	-
3	1,0	1,1
5	1,8	1,9
10	2,8	2,9
2	1,0	1,1
4	1,8	1,9
8	3,1	3,4
12	4,1	4,7
20	6,3	7,0
35	10,5	12,0
55	18,2	20,6
70	22,4	26,5
100	31,2	35,8
150	44,4	52,8
250	59,0	84,0
400	107,0	135,0

OPERATING TIME (sec)

SIZE	"DA" OPEN	"DA" CLOSE	"SR" OPEN	"SR" CLOSE
1	<1	<1	-	-
3	<1	<1	<1	<1
5	<1	<1	<1	<1
10	<1	<1	<1	<1
2	<1	<1	<1	<1
4	<1	<1	<1	<1
8	<1	<1	<1	<1
12	1,5	1,5	1,5	1,0
20	2,0	2,0	2,0	1,5
35	2,5	2,5	2,5	2,0
55	3,5	3,5	3,5	3,0
70	4,0	4,0	4,0	3,0
100	4,5	4,5	5,5	3,0
150	5,0	5,0	7,0	4,0
250	7,0	7,0	8,0	5,0
400	12,0	12,0	13,0	10,0

* Note! May be affected by air pipe diameter and type of solenoid valve

AIR CONSUMPTION (90°)

SIZE	OPEN (litre)	CLOSE (litre)	OPEN (ci)	CLOSE (ci)
1	0,04	0,06	2,44	3,65
3	0,09	0,12	5,49	7,32
5	0,18	0,24	10,98	14,65
10	0,34	0,41	23,18	30,52
2	0,49	0,64	5,49	7,32
4	0,90	1,00	10,98	14,65
8	0,34	0,41	20,80	25,02
12	0,49	0,64	29,90	39,05
20	0,90	1,00	54,92	61,02
35	1,69	1,90	103,12	115,94
55	2,80	3,40	170,86	207,47
70	3,05	3,70	186,12	225,79
100	5,52	5,90	336,85	360,04
150	7,60	9,60	463,78	585,83
250	8,50	9,80	518,03	598,03
400	13,60	17,50	892,92	1067,92





TruTorq

Orders and Inquiries

**order@wirematic.se
info@wirematic.se**

**www.trutorq-automation.com
for our complete network of suppliers**

**Wirematic TruTorq AB
Krossgatan 22b
162 50 Vällingby
Stockholm - Sweden**